

Performance Parameters & Limited Warranty

“Seller” and/or “Stearns” refers to Rexnord Industries, LLC (which sells products and services under the Stearns brand) for the entirety of this catalog, warranty, products, and services.

The performance of Stearns brakes, clutches, clutch-brake combinations, solenoids, and controls depends upon the proper application of the product, adequate run in, installation and maintenance procedures, and reasonable care in operation.

All torque values listed in our bulletins are nominal and are subject to the variations normally associated with friction devices. The purchaser should take into consideration all variables shown in the applicable specification sheets. Although our application engineers are available for consultation, final selection and performance assurance on the purchaser’s machine is the responsibility of the purchaser. Careful purchaser selection, adequate testing at time of installation, operation and maintenance of all products of the seller are required to obtain effective performance.

Stearns warrants to its purchasers that all its products will be free from defects in material and workmanship at the time of shipment to the purchaser for a period of one (1) year from the date of shipment. All warranty claims must be submitted in writing to Stearns within the warranty period, or shall be deemed waived. As to products or parts thereof which Stearns finds to have been defective at the time of shipment, its sole responsibility hereunder shall be to repair, correct or replace (whichever Stearns deems advisable) such defective products or parts without charge, FOB Stearns factory. In the alternative, Stearns may, at its option, either before or after attempting a different remedy, refund the purchase price upon return of the product or parts.

This warranty shall not apply to any product which has been subjected to misuse: misapplication: neglect (including but not limited to improper maintenance and storage); accident: improper installation; modification (including but not limited to use of other than genuine Stearns replacement parts or attachments); adjustment; or repair.

THE FOREGOING IS IN LIEU OF ALL OTHER WARRANTIES, WHETHER EXPRESSED, IMPLIED, OR STATUTORY, INCLUDING THAT OF MERCHANTABILITY AND OF FITNESS FOR A PARTICULAR PURPOSE, AND OF ANY OTHER OBLIGATION OR LIABILITY ON OUR PART OF ANY KIND OR NATURE WHATSOEVER.

No Stearns representative has any authority to waive, alter, vary or add to the terms hereof without prior approval in writing, to our purchaser, signed by an officer of the seller.

Stearns liability for its products, whether for breach of contract, negligence, strict liability in tort, or otherwise, shall be limited to the repair, correction, or replacement of the products or parts thereof, or to the refund of the purchase price of such products or parts. Stearns will not be liable for any other injury, loss, damage or expense, whether direct or consequential, including but not limited to loss of use, income, profit or production, or increased cost of operation, or spoilage of or damage to material, arising in connection with the sale, installation, use of, inability to use, or the repair or replacement of, or late delivery of, Stearns products.

Any cause of action for breach of the foregoing warranty must be brought within one (1) year from the date the alleged breach occurs.

Note on Special Applications:

Stearns products are designed for standard industrial and commercial applications. Operating requirements, environments and required tolerances such as in nuclear and aircraft applications may be beyond the commercial standards of the Stearns Divisions products. Stearns will assume absolutely no responsibility for the use of and/or resale of Stearns products for such applications unless approved in writing in advance by Stearns.

View the most up-to-date terms and conditions at www.regalrexnord.com/terms-and-conditions-of-sale.

Marine, Maritime & Navy Brakes

Solenoid-Actuated Brakes

	Marine		Marine		Maritime		Navy
Description	Suitable for many shipboard and severe duty applications		Suitable for many shipboard and severe duty applications		Suitable for many Coast Guard, shipboard and severe duty applications when "ductile iron" is specified		Designed to Military Specification
Compliance (Note A)	IEEE 45 ABS		IEEE 45 ABS		IEEE 45 Federal Standard 46 ABS		MIL-DTL-16392D (Ships)
Spring Set Operation (Note E)	Armature Actuated Brake (AAB)		Solenoid Actuated Brake (SAB)				
Stearns Series (Note B)	350	360	1-056-200-K0	1-087-0xx-K0 1-082-0xx-K0 1-086-0xx-K0	1-087-Mxx	1-082-4xx 1-086-4xx	1-087-6xx 1-082-6xx 1-086-6xx
IP Rating	IP 56	IP 56	IP 54/56*	IP 56 (Note C)	IP 56		IP 56
Enclosure Finish	DI - Water Based Primer Alum - anodize MIL-A-8525 F		Water Based Primer		Alkyd Primer MIL TT-P-645C		Enamel MIL-E-15090
Coil	Class 180(H)		Class 180(H)		Class 180(H)		Class 180(H)
Endplate or Mount Plate Material	Steel		Cast Iron		Ductile Iron		Ductile Iron
Housing Material	Cast Aluminum or Ductile Iron		Cast Iron		Ductile Iron		Ductile Iron
Support Plate Material	N/A		Steel	(Note H)	Ductile Iron		Ductile Iron
Pressure Plate & Stationary Disc Material	N/A		Brass		Brass		Brass
Self Adjusting (Note G)	No, Gap By Gage		No, Gap By Scale	Yes	Yes		Yes
Manual Release (Note D)	Optional		Maintained		Maintained		Non-Maintained

- A. IEEE 45 compliance nameplate is optional. ABS certificate SB374021.
 B. Additional options and modifications are included in the full 12 digit part number.
 C. IP 56 with side release option available in 1-087-000-K0 and 1-082-000-K0.
 D. The maintained release holds the brake in a release condition until the brake is electrically, or manually, re-engaged. The non-maintained ("deadman") release is manually held in the released condition, re-setting when the force is removed.
 E. Spring-set, solenoid with coil and linkage actuated brake (SAB), AC voltage coil. Spring-set, armature actuated direct-acting brake (AAB), DC voltage coil.
 F. Carrier ring friction disc is standard with the 350 and 360 series and is an option in the SAB brakes.
 G. Stainless steel self-adjust is standard with the 1-08x-600 and 1-087-M00.
 H. 1-087: cast aluminum; 1-082: cast iron; 1-086: ductile iron.
 I. Dimensions may differ from catalog brakes; dimensional drawings available on request.
 *IP 54; IP 56 with motor gasket.

Armature-Actuated Brakes

MIL-B-16392C is inactive for new design and is no longer required, except for replacement purposes, per statement issued by Naval Sea Systems Command in June of 2001. The armature-actuated brake (AAB) was designed in consultation with Naval specification authorities as a suitable commercial off the shelf (COTS) motor brake.

Series 350 Pressure Plate Mount Internal Maintained Manual Release

Torque (lb-ft)	Model Number	NEMA Frame Size
75	3-51-734H0	182TC-256TSC
110	3-51-744H0	182TC-256TSC
110	3-51-744J0	284TC-286TSC
110	3-51-744K0	324TC-405TSC
180	3-51-844J0	284TC-286TSC
180	3-51-844K0	324TC-405TSC
300	3-51-944k0	324TC-405TSC

Series 360 Magnet Body Mount Internal Maintained & Optional External Non-Maintained Manual Release

Torque (lb-ft)	Model Number	NEMA Frame Size
60	3-61-644H0	182TC-256TSC
60	3-61-644J0	284TC-286TSC
75	3-61-734H0	182TC-256TSC
110	3-61-744H0	182TC-256TSC
110	3-61-744J0	284TC-286TSC
180	3-61-844J0	284TC-286TSC
180	3-61-844K0	324TC-405TSC
300	3-61-944K0	324TC-405TSC
300	3-61-944L0	444TC

Mining Brakes: MSHA Certified

Stearns 1-082-3X4-06 series of electric fail-safe motor brakes are now certified for use in underground mines by the federal Mine Safety and Health Administration (MSHA).

Stearns is the only supplier of MSHA certified motor brakes.

MSHA approves and certifies products for use in underground coal and gassy mines to ensure that they do not cause a fire or explosion.

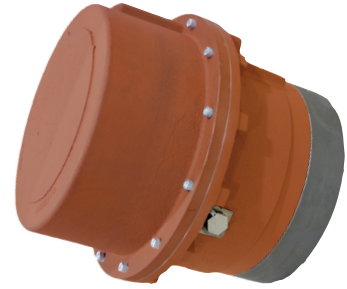

Static Torque: 125 through 330 lb-ft

IP Rating: 56

Enclosure Material: Cast iron

Enclosure Type: UL Type 4

Manual Release Type: Side lever, latching with automatic reset when electric power is applied to the brake coil.

Mounting Face: 12.5" AK, 11.0" AJ (NEMA 324 and 326 TC, NEMA 364 and 365 TC, NEMA 404 and 405 TC).

Modifications: See SAB modifications section.

Features

- Spring-set electrically released
- Self-adjust design: automatic adjustment for friction disc wear to reduce maintenance
- Fanguard mounted
- Coil insulation: Class 180(H)
- Thermal cut-out switch
- Electrical connections terminate at terminal block
- MSHA certification number: 18-XPA070006-0

Options

- Internal encoder
- Internal electric heater
- Electrical release indicator switch
- Carrier ring friction discs

Model No. IP56	No. of Discs	Torque Lb-Ft	C	**L	SL
1-082-314-06	2	125	5.72	4.63	5.65
1-082-324-06	2	175	5.72	4.63	5.65
1-082-334-06	3	230	6.22	5.13	6.15
1-082-344-06	3	330	6.22	5.13	6.15

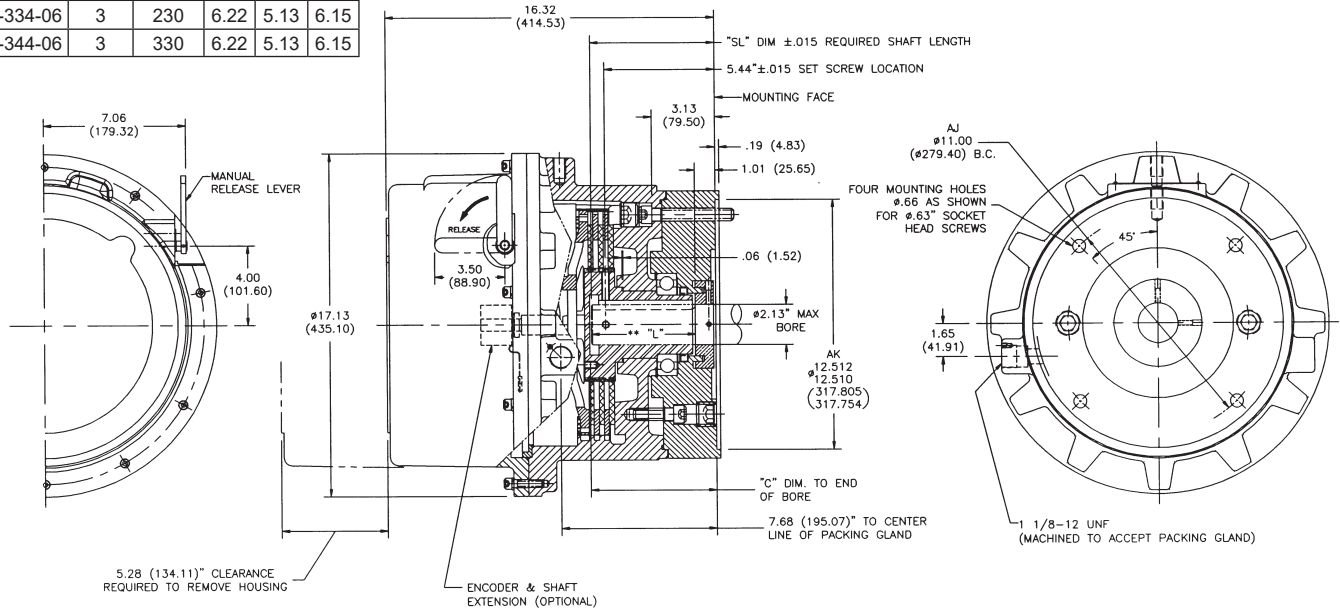

** "L" DIM. APPLIES TO MAXIMUM KEYWAY SLOT LENGTH.

Ordering Information - specify¹:

- Model Number
- Bore & keyway²
- Voltage²
- Options
- Leadwire packing gland - left or right (looking towards brake mounting face). Note: encoder option requires that the encoder wiring enters the brake from the opposite side of all of the other brake wiring.

Model No.	IP Rating	Enclosure	Nominal Static Torque lb-ft (Nm)
1-082-314-06	IP 56	UL Type 4	125 (169)
1-082-324-06	IP 56	UL Type 4	175 (237)
1-082-334-06	IP 56	UL Type 4	230 (312)
1-082-344-06	IP 56	UL Type 4	330 (447)

¹ These brakes need to be purchased from the motor manufacturer, as the required shaft length (dimension "SL" above) is not standard.

² Refer to 82,300 Series section.

Encoder Brakes

Stearns Solenoid Actuated Brakes with Internally Mounted Encoder

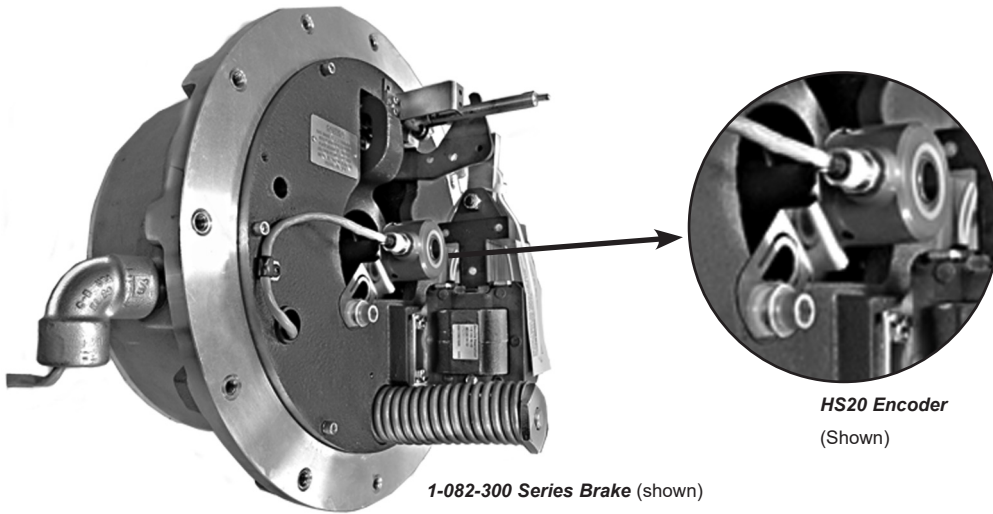

Features

- Available in frame sizes 182TC - 505TC
- All IP ratings available, including hazardous location
- Separate conduit exits are provided for the brake and encoder leads to minimize potential electrical interference
- Choice of popular encoder manufacturers

Benefits

- Encoder located in protected environment enclosed inside the brake housing
- Simplified encoder mounting
- Reduced package length - an internal encoder does not add any length to the brake
- Lower installed cost

Ordering Information

Stearns brakes with internal encoders are purchased through the motor manufacturer, as the required shaft length and diameter are non-standard. An internal encoder is not a retrofit option, like a brake coil, heater or switch. To order the brake motor package, specify the brake model and encoder option from table on following page.

Encoder Brakes Continued

Stearns Solenoid Actuated Brakes with Internally Mounted Encoder

Ordering Information

For Stearns solenoid actuated brakes (SABs) with internal encoders.

Industrial Locations

Frame Size	Brake Series	Torque Range lb-ft	Encoder Options ¹	Connector / Cable ²	Stearns Drawing No. ³
182TC - 256TC	1-087-EX2	25 - 105	Dynapar HS20 BEI HS20 BEI HS25	M12, 8 Pin / 15' M12, 8 Pin / 5m 10 Pin / 20'	1087E00ED 1087E00ED
324TC - 405TC	1-081-XXX	125 - 230	Dynapar HS20 BEI HS20 BEI HS25	M12, 8 Pin / 15' M12, 8 Pin / 5m 10 Pin / 20'	10810022ED 10810022ED
324TC - 405TC	1-082-XXX	125 - 440	Dynapar HS20 BEI HS20 BEI HS25	M12, 8 Pin / 15' M12, 8 Pin / 5m 10 Pin / 20'	10820022ED 10820022ED
444TC - 505TC	1-086-XXX	500 - 1000	Dynapar HS20 BEI HS20 BEI HS25 BEI HS35M	M12, 8 Pin / 15' M12, 8 Pin / 5m 10 Pin / 20' 10 Pin MS / 15'	10860022ED 10860022ED 10860022ED 10860022E35D

Division 1 Hazardous Location⁴

182TC - 256TC	1-087-3X8	10 - 105	Dynapar HS20 BEI HS20	M12, 8 Pin / 15' M12, 8 Pin / 5m	1087308D ⁵ 1087308D ⁵
324TC - 405TC	1-082-3X4	125 - 330	Dynapar HS20 BEI HS20	M12, 8 Pin / 15' M12, 8 Pin / 5m	1082304D ⁶ 1082304D ⁶

¹ Encoders are Optical, 1024 PPR. Options shown or factory approved equivalents may be used.

² Cables are shielded. Lengths are from encoder connector, inside the brake (not from outside of brake housing).

³ Request this drawing for shaft design requirements.

⁴ No motor shaft modifications required, beyond the brake requirements for a standard hazardous location brake.

⁵ Drawing 1087308D brake model mounts close-coupled to the motor end bell.

For the brake model that mounts to the motor fanguard, refer to drawing 10873081D.

For the brake model that mounts to the motor fanguard - with a slinger - refer to drawing 10873052D.

⁶ Drawing 1082304D brake model mounts close-coupled to the motor end bell.

For the brake model that mounts to the motor fanguard, refer to drawing 10823042D.

In addition to the fully enclosed brake with internal encoder options, encoders can be adapted externally to Stearns brakes:

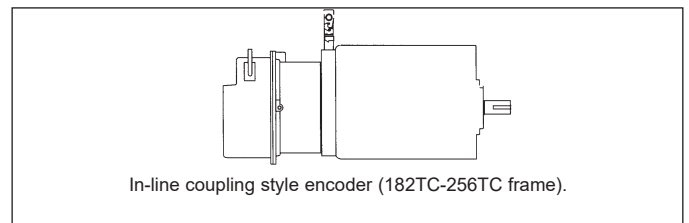
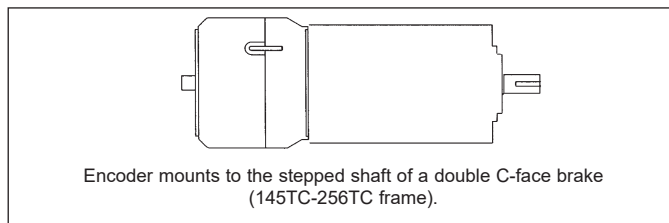
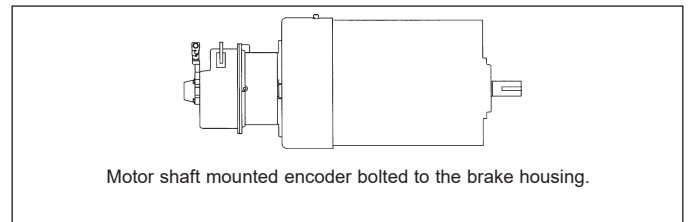
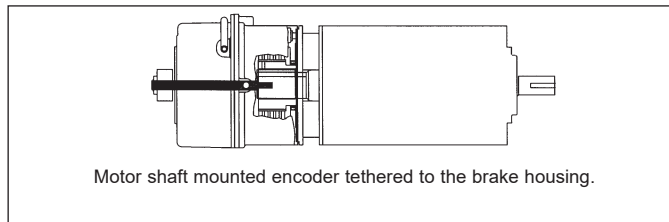

Technical Data

SAB Motor Frame Adapter Dimensions Selection

To select an adapter for a specific brake, refer to the motor frame adapter tables as shown in the brake series sections of this catalog. After selecting the adapter stock number, refer to the Tables below for dimensions.

All adapters are constructed with an opening for internal lead wire connection, corresponding to the NEMA standard location for the motor frame size.

Screws for mounting adapter to motor must be provided by customer. Socket head cap screws are supplied for mounting brake to adapter.

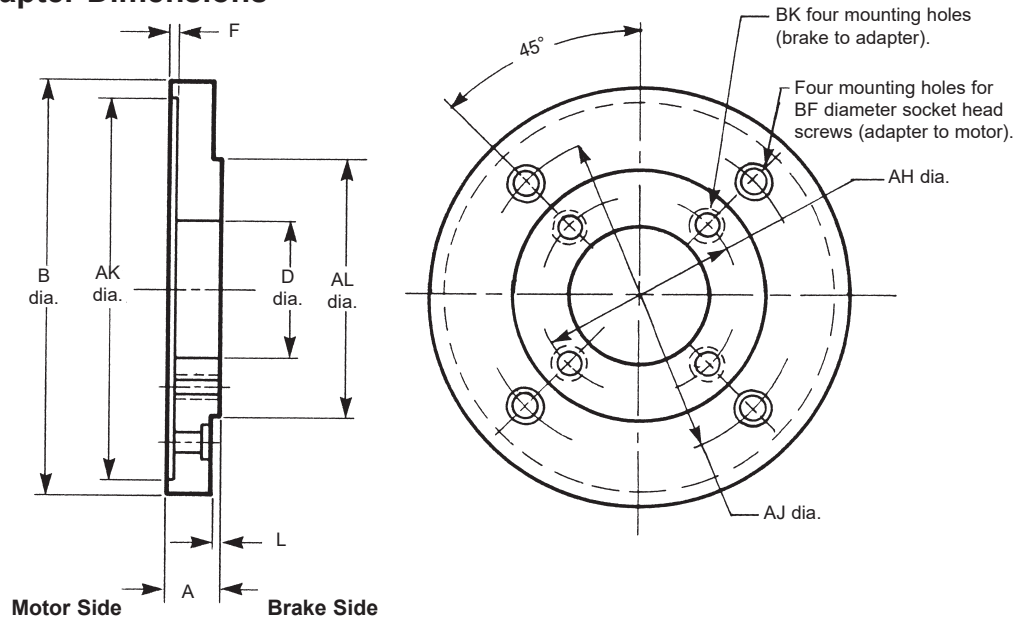

Dimensions for estimating only. For installation purposes, request certified prints.

Brake Series	Torque (lb-ft)	Adapter Stock Number	Dimensions in Inches (Dimensions in Millimeters)											Add'l Shaft Length Req'd			
			A	AH	AJ	AK	AL	B	BF	BK Hole	D	F	L				
56,000	1.5 - 6	5-55-5041-00				8.500	4.497										
65,300*		5-55-5046-00	1.25 (31.75)	5.88 (149.22)	7.25 (184.15)	8.502 (215.900) (215.951)	4.500 (114.325) (114.275)	9.00 (228.60)	.50 (12.70)	3/8 - 16 x 1/2 deep	4.00 (101.60)	.19 (4.76)	.12 (3.18)	.94 (23.88)			
56,000 and 56,800*	10 - 25	5-55-5043-00															
87,000 and 87,800*	6 - 105	5-55-7046-00	1.06 (26.99)		11.00 (279.40)	12.501 (317.525) (317.602)	8.499 (215.875) (215.849)	13.00 (330.20)	.62 (15.88)		4.12 (104.78)			.38 (9.52)	.87 (22.10)		
87,300		5-55-7054-00		7.25 (184.15)						1/2 - 13 through		.19 (4.76)					
87,000 and 87,800*	6 - 105	5-55-7055-00	1.00 (25.40)		9.00 (228.60)	10.500 (266.700) (266.751)	8.499 (215.875) (215.849)	11.00 (279.40)	**		6.25 (158.75)			.25 (6.35)	.81 (20.57)		
87,300*		5-55-7045-00															
87,000, 87,800* and 87,300*	6 - 105	5-55-7043-00	.75 (19.05)	7.25 (184.15)	5.88 (149.35)	4.502 (114.35) (114.48)	8.499 (215.875) (215.849)	8.75 (222.25)	.62 (15.75)	1/2 - 13 through	4.00 (101.60)	.19 (4.76)	.25 (6.35)	.56 (14.23)			
81,000	125 - 130	5-55-2045-00	1.06 (26.99)	11.00 (279.40)	14.00 (355.60)	16.002 (406.451) (406.527)	12.499 (317.475) (317.398)	16.50 (419.10)	.62 (15.88)	5/8 - 11 through	9.75 (247.65)	.19 (4.76)	.25 (6.35)	.87 (22.10)			
81,000	125 - 230	5-55-2041-00			7.25 (184.15)	8.500 (215.900) (215.951)	12.499 (317.475) (317.398)	12.496 (317.475) (317.398)	.50 (12.70)	5/8 - 11 through	6.00 (152.40)			.93 (23.62)			
81,000		5-55-2043-00	1.12 (28.58)	11.00 (279.40)	9.00 (228.60)	10.500 (266.700) (266.751)	12.496 (317.398)	12.496 (317.398)			7.75 (196.85)	.19 (4.76)		.93 (23.62)			
82,000 and 82,300*	125 - 440	5-55-2046-00	1.94 (49.21)		14.00 (355.60)	16.002 (406.451) (406.527)		16.50 (419.10)	.62 (15.88)	5/8 - 11 x 1 deep	9.50 (241.30)			1.75 (44.45)			
82,000 and 82,300*		5-55-2042-00	1.38 (34.92)	11.00 (279.40)	7.25 (184.15)	8.500 (215.900) (215.951)	12.499 (317.475) (317.398)	13.25 (336.55)	.50 (12.70)	5/8 - 11 through	6.00 (152.40)	.19 (4.76)	.25 (6.35)	1.19 (30.23)			
82,000 and 82,300*		5-55-2044-00	1.38 (34.92)		9.00 (228.60)	10.500 (266.700) (266.751)		13.25 (336.55)			7.75 (196.85)			1.19 (30.23)			
86,000	500 - 1000	5-55-6041-00	1.56 (38.69)	14.00 (355.60)	11.00 (379.40)	12.500 (317.500) (317.602)	16.000 (406.400) (406.273)	16.19 (411.16)	.62 (15.88)	5/8 - 11 x 3/4 deep	8.62 (219.08)	.19 (4.76)	.25 (6.35)	1.37 (34.80)			

* 1/2-13 flat head screws are supplied with adapter.

** When adding an adapter to a hazardous location brake, refer to the "mounting requirements" on the product page for the recommended brake series for accommodating adapters.

Foot Mounting Kits

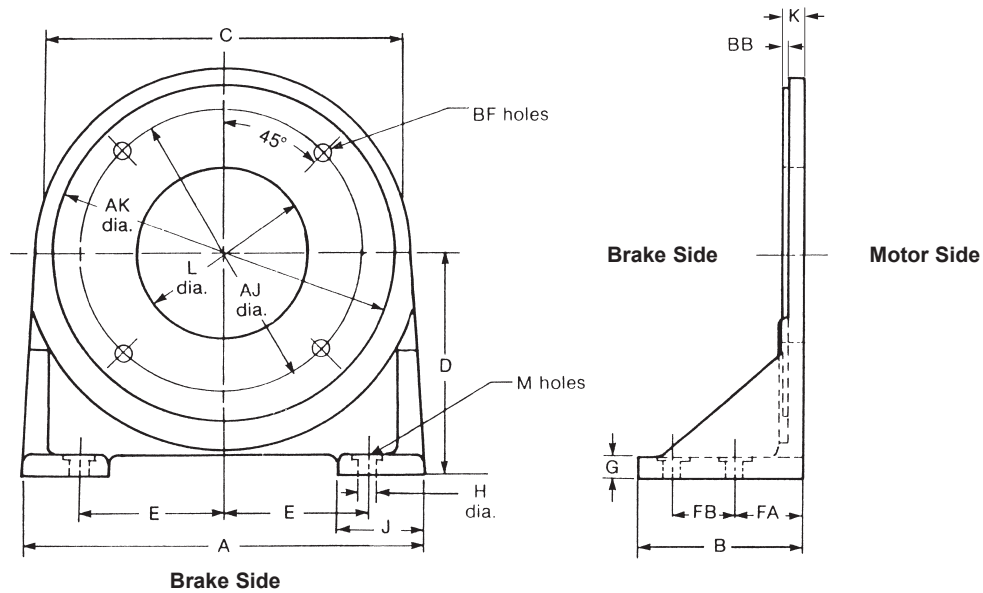

Kits include the foot mounting bracket and hardware to fit the BF mounting holes.

Dimensions for estimating only. For installation purposes, request certified prints.

Brake Series	Torque	Foot Mounting Kit Number	Dimensions in Inches (Dimensions in Millimeters)																	Wgt lbs.	
			A	AJ	AK	B	BB	BF		C	D	E	FA	FB	G	H	J	K	L		M
								No.	Thd.												
56,000	1.5-25	5-55-5023-00	7.00 (177.80)	5.88 (149.22)	$\frac{4.499}{4.498}$ ($\frac{114.275}{114.249}$)	2.38 (60.32)	.12 (3.18)	2	3/8-16	6.50 (165.10)	3.50 (88.90)	2.88 (73.02)	1.50 (38.10)	-	.38 (9.52)	.41 (10.32)	1.50 (38.10)	.50 (12.70)	2.50 (63.50)	2	4.5
87,000	6-125	5-55-7021-00	8.62 (219.08)	7.25 (184.15)	$\frac{8.499}{8.498}$ ($\frac{215.875}{215.849}$)	3.00 (76.20)	.25 (6.35)	4	1/2-13	8.62 (218.95)	5.00 (127.00)	3.56 (90.49)	2.00 (50.80)	-	.38 (9.52)	.53 (13.49)	1.62 (41.28)	.56 (14.29)	5.75 (146.05)	2	7
81,000	125-230	5-55-2022-00	15.50 (393.70)	11.00 (279.40)	$\frac{12.499}{12.498}$ ($\frac{317.475}{317.449}$)	7.00 (177.80)	.25 (6.35)	4	5/8-11	13.25 (336.55)	8.50 (215.90)	6.88 (174.62)	2.00 (50.80)	4.00 (101.60)	.62 (15.88)	.69 (17.46)	3.00 (76.20)	.88 (22.22)	9.00 (228.60)	4	40
82,000	125-550		18.25 (463.55)	14.00 (355.60)	$\frac{16.000}{15.995}$ ($\frac{406.400}{406.273}$)	8.00 (203.20)	.22 (5.56)	4	5/8-11	17.00 (431.80)	10.88 (276.22)	6.38 (161.92)	3.38 (85.72)	3.00 (76.20)	1.00 (25.40)	.81 (20.64)	4.12 (104.78)	1.22 (30.96)	8.50 (215.90)	4	75

Dimensions for C-Face Brake Motor Systems

Brakes Externally Wired to Motor
C-face motor with double shaft extension.

Stearns disc brakes are designed to mount on standard C-face motors having the same dimensions and tolerances on the accessory end as on the drive end. They also mount on foot mounting brackets and machine mounting faces having the same mounting dimensions and tolerances. Some motor accessory end C-face may differ from the drive end.

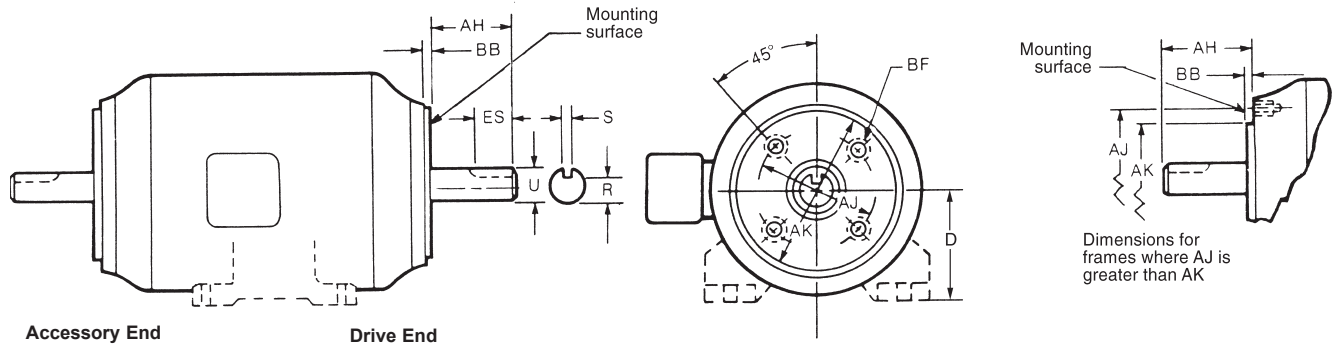

Drive End Dimensions (Inches)

Frame Designation	AJ	AK	BB Min.	BF Hole			U	AH	Keyseat			Base to Centerline D
				Number	Tap Size	Bolt Penetration Allowance			R	ES Min.	S	
42C	3.750	3.000	0.16	4	1/4-20	...	0.375	1.312	0.328	...	flat	2.62
48C	3.750	3.000	0.16	4	1/4-20	...	0.500	1.69	0.453	...	flat	3.00
56C	5.875	4.500	0.16	4	3/8-16	...	0.625	2.06	0.517	1.41	0.188	3.50
143TC and 145TC	5.875	4.500	0.16	4	3/8-16	0.56	0.875	2.12	0.771	1.41	0.188	3.50
182TC and 184TC	7.250	8.500	0.25	4	1/2-13	0.75	1.125	2.62	0.986	1.78	0.250	4.50
182TCH and 184TCH	5.875	4.500	0.16	4	3/8-16	0.56	1.125	2.62	0.986	1.78	0.250	4.50
213TC and 215TC	7.250	8.500	0.25	4	1/2-13	0.75	1.375	3.12	1.201	2.41	0.312	5.25
254TC and 256TC	7.250	8.500	0.25	4	1/2-13	0.75	1.625	3.75	1.416	2.91	0.375	6.25
284TC and 286TC	9.000	10.500	0.25	4	1/2-13	0.75	1.875	4.38	1.591	3.28	0.500	7.00
284TSC and 286TSC	9.000	10.500	0.25	4	1/2-13	0.75	1.625	3.00	1.416	1.91	0.375	7.00
324TC and 326TC	11.000	12.500	0.25	4	5/8-11	0.94	2.125	5.00	1.845	3.91	0.500	8.00
324TSC and 326TSC	11.000	12.500	0.25	4	5/8-11	0.94	1.875	3.50	1.591	2.03	0.500	8.00
364TC and 365TC	11.000	12.500	0.25	8	5/8-11	0.94	2.375	5.62	2.021	4.28	0.625	9.00
364TSC and 365TSC	11.000	12.500	0.25	8	5/8-11	0.94	1.875	3.50	1.591	2.03	0.500	9.00
404TC and 405TC	11.000	12.500	0.25	8	5/8-11	0.94	2.875	7.00	2.450	5.65	0.750	10.00
404TSC and 405TSC	11.000	12.500	0.25	8	5/8-11	0.94	2.125	4.00	1.845	2.78	0.500	10.00
444TC and 445TC	14.000	16.000	0.25	8	5/8-11	0.94	3.375	8.25	2.880	6.91	0.875	11.00
444TSC and 445TSC	14.000	16.000	0.25	8	5/8-11	0.94	2.375	4.50	2.021	3.03	0.625	11.00
500 Frame Series	14.500	16.500	0.25	4	5/8-11	0.94	12.50

Tolerances (Inches)

AK Dimension, Face Runout, Permissible Eccentricity of Mounting Rabbet

AK Dimension	Tolerance on AK Dimension		Maximum Face Runout	Maximum Permissible Eccentricity of Mounting Rabbet
	Plus	Minus		
Less than 12	0.000	0.003	0.004	0.004
12 and Larger	0.000	0.005	0.007	0.007

Shaft Extension Diameters

Shaft Diameter	Tolerances	
	Plus	Minus
0.2500 to 1.5000, inclusive	0.000	0.0005
Over 1.5000 to 6.500, inclusive	0.000	0.001

Width of Shaft Extension Keyseats

Width of Keyseat	Tolerances	
	Plus	Minus
0.188 to 0.750, inclusive	0.002	0.000
Over 0.750 to 1.500, inclusive	0.003	0.000

Shaft Runout

Shaft Diameter	Maximum Permissible Shaft Runout
0.3750 to 1.625, inclusive	0.002
Over 1.625 to 6.500, inclusive	0.003

SOURCE: ANSI/NEMA Standards Publication No. MG 1-1987; Part 4 and Part 11.

Dimensions for C-Face AC Brake Motor Systems Continued

Accessory End

FC face mounting for accessories, including brakes, on the end opposite the drive end of motor. Some motor accessory end C-face may differ from the drive end. Confirm shaft diameter and bolt circle before ordering.

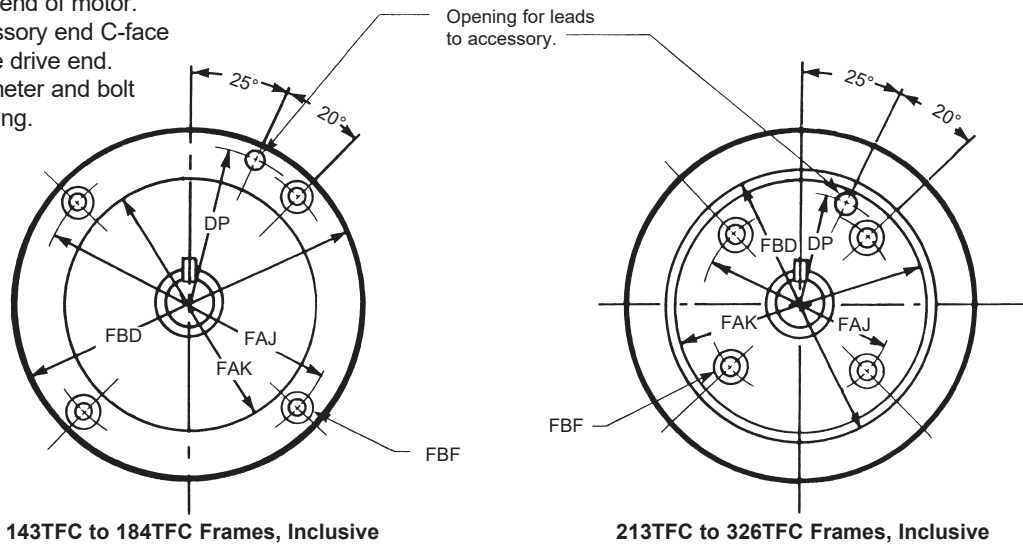

Dimensions (Inches)

Frame Designation	FAJ	FAK	FBD Max.	FBF Hole			Hole for Accessory Leads	
				Number	Tap Size	Bolt Penetration Allowance	DP	Diameter
143TFC and 145TFC	5.875	4.500	6.50	4	3/8-16	0.56	2.81	0.41
182TFC and 184TFC	5.875	4.500	6.50	4	3/8-16	0.56	2.81	0.41
213TFC and 215TFC	7.250	8.500	9.00	4	1/2-13	0.75	3.81	0.62
254TFC and 256TFC	7.250	8.500	10.00	4	1/2-13	0.75	3.81	0.62
284TFC and 286TFC	9.000	10.500	11.25	4	1/2-13	0.75	4.50	0.62
324TFC and 326TFC	11.000	12.500	14.00	4	5/8-11	0.94	5.25	0.62

NOTE: Standards have not been developed for the shaft extension diameter and length, and keyseat dimensions.

Tolerances* (Inches)

FAK Dimension, Face Runout, Permissible Eccentricity of Mounting Rabbet

FAK Dimension	Tolerance on FAK Dimension		Maximum Face Runout	Maximum Permissible Eccentricity of Mounting Rabbet
	Plus	Minus		
Less than 12	0.000	0.003	0.004	0.004
12 and Larger	0.000	0.005	0.007	0.007

* Tolerance requirement on 56,X00 and 87,000 Series brake kits is .015 T.I.R. (total indicated runout shaft to motor register face).

Shaft Runout

Shaft Diameter	Maximum Permissible Shaft Runout
0.3750 to 1.625, inclusive	0.002
Over 1.625 to 6.500, inclusive	0.003

SOURCE: ANSI/NEMA Standards Publication No. MG 1-1987; Part 4 and Part 11.

Stearns Recommended Minimum Shaft Diameter by Torque

Minimum recommended shaft size considers a keyed C1045 steel shaft under dynamic use in a typical spring set brake application.

Torque ft-lb	Minimum Shaft (inches)
0.50	0.250
0.75	0.250
1.5	0.375
3	0.500
6	0.500
10	0.625
15	0.750
25	0.875
35	1.000
50	1.125

Torque ft-lb	Minimum Shaft (inches)
75	1.250
105	1.375
125	1.375
175	1.625
230	1.750
330	2.000
440	2.125
500	2.375
750	2.500
1000	2.750

Torque Nm	Minimum Shaft (mm)
4 Nm	ø10 mm
8 Nm	ø13 mm
16 Nm	ø16 mm
32 Nm	ø20 mm
60 Nm	ø25 mm
80 Nm	ø28 mm
150 Nm	ø34 mm
240 Nm	ø39 mm
400 Nm	ø47 mm

Set & Release Times

The models listed below were tested for typical set and release times. Times listed below are defined as follows:

T1 = Total set time to 80% of rated static torque T2 = Release time, measured as the time from when the power is applied to the brake to the time that the solenoid plunger or armature is fully seated.

NOTE: Times will vary with the motor used, and brakes tested with factory-set air gap. The times shown should be used as a guide only.

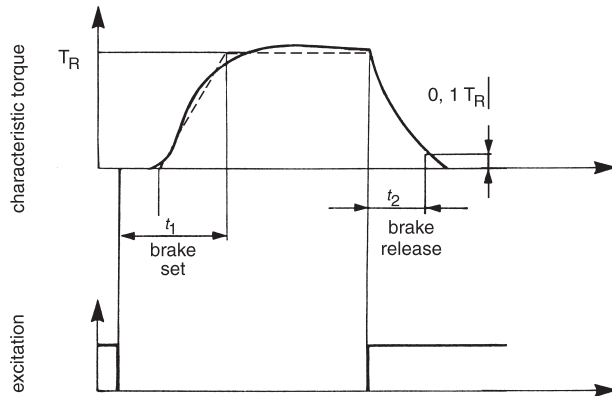

SAB T1/T2 Time in Milliseconds

Series	Static Torque lb-ft	Coil Size	Coil Strength	T1 AC	T2 AC
56,000	1 1/2 – 25	4	3	25	14
87,000	10,15, 25,50	5 & 6	3	53	21
87,000	35,75,105	8	3	50	25
81,000 82,000	All	9	3	58	31

Brake and motor are switched separately.
All brakes tested in horizontal position.
Coil is energized for >24 hours before testing.
Ambient temperature 70°F at time of test.

AAB Series 310/311/320/321 Times in Milliseconds

Series	310 DC Side Switching					
Size	1.79	2.0	2.87	3.35	4.25	5.0
T1	3	6	9	14	13	22
T2	20	43	48	110	120	195
Series	311 DC Side Switching					
Size	3.38	4.75	5.0			
T1	43	48	96			
T2	12	74	35			
Series	320 DC Side Switching					
Size	1.2	1.8	2.0	2.8		
T1	14	43	16	27		
T2	24	26	35	34		
Series	320 Full wave rectifier/AC Side Switching					
Size	1.2	1.8	2.0	2.8		
T1	31	97	52	78		
T2	27	29	40	42		
Series	321 DC Side Switching			321 AC Side Switching		
Size	1.2	1.8	2.8	1.2	1.8	2.8
T1	13	16	20	45	77	131
T2	18	27	49	16	25	26

AAB Series 333 Times in Milliseconds

Size	Applied Voltage/Type of Switching	T1	T2
72	DC side switching	23	35
	230 Vac/ac side switching/full wave	103	39
	460 Vac/ac side switching/half wave	98	34
90	DC side switching	19	73
	230 Vac/ac side switching/full wave	113	72
	460 Vac/ac side switching/half wave	114	73
	230 Vac connected across motor full wave	357	72
112	230 Vac connected across motor /quickset	42	72
	DC side switching	155	39
	230 Vac/ac side switching/full wave	547	43
	460 Vac/ac side switching/half wave	501	54
132	DC side switching	119	100
	230 Vac/ac side switching/full wave	833	101
	460 Vac/ac side switching/half wave	803	106
145	DC side switching	185	186
	230 Vac/ac side switching/full wave	999	192
	460 Vac/ac side switching/half wave	1007	209
	230 Vac connected across motor full wave	1689	192
	230 Vac connected across motor /quickset	368	192
170	460 Vac/ac side switching/half wave/With air gap shim	629	223
	DC side switching	129	163
	230 Vac/ac side switching/full wave	1130	174
	460 Vac/ac side switching/half wave	1140	175
	DC side switching	96	263
	230 Vac/ac side switching/full wave	920	264
196	460 Vac/ac side switching/half wave	957	274
	DC side switching	131	264
	230 Vac/ac side switching/full wave	1299	236
230	460 Vac/ac side switching/half wave	1303	276
	Tor-Ac 230 Vac/ac side switching/full wave	169	295
	Tor-Ac 230 Vac/ac side switching/full wave/With air gap shim	122	327
	230 Vac connected across motor quickset/quickrelease/with air gap shim	122	145
	DC side switching	182	388
278	230 Vac/ac side switching/full wave	1807	389
	460 Vac/ac side switching/half wave	1689	366

Conversions

English-Metric Conversion Factors

Multiply the base unit by the factor shown to obtain the desired conversion.

Measurement	Base Unit	Factor	Conversion
Length	inch, in	25.4	(<i>millimeter, mm</i>)
	(<i>millimeter, mm</i>)	.03937	inch, in
Torque	pound-feet, lb-ft	1.355818	(<i>newton-meter, Nm</i>)
	(<i>newton-meter, Nm</i>)	.73756	pound-feet, lb-ft
	pound-inch, lb-in	.113	(<i>newton-meter, Nm</i>)
	(<i>newton-meter, Nm</i>)	8.85	pound-inch, lb-in
	ounce-inch, oz-in	.007062	(<i>newton-meter, Nm</i>)
	(<i>newton-meter, Nm</i>)	141.611	ounce-inch, oz-in
Moment of Inertia	pound-feet squared, lb-ft ²	.04214	(<i>kilogram-meter squared, kgm²</i>)
	(<i>kilogram-meter squared, kgm²</i>)	23.73	pound-feet squared, lb-ft ²
Kinetic Energy	foot-pound, ft-lb	1.355818	(<i>joule, J</i>)
	(<i>joule, J</i>)	.73756	foot-pound, ft-lb
Weight	pound, lb	.453592	(<i>kilogram, kg</i>)
	(<i>kilogram, kg</i>)	2.20462	pound, lb
Horsepower (English)	horsepower, hp	.7457	(<i>kilowatt, kW</i>)
	(<i>kilowatt, kW</i>)	1.341	horsepower, hp
Thermal Capacity	horsepower-seconds per minute, hp-sec/min	12.42854	(<i>watts W</i>)
	(<i>watts, W</i>)	.08046	horsepower-seconds per minute, hp-sec/min
Temperature	degrees Fahrenheit, °F	(°F - 32) x 5/9	(<i>degrees Celsius, °C</i>)
	(<i>degrees Celsius, °C</i>)	(°C x 9/5) + 32	degrees Fahrenheit, °F

English-English Conversion Factors for Thermal Capacity

Base Unit	Multiply by	To Obtain
horsepower	60.0	hp-sec/min
ft-lb/sec	.109	hp-sec/min
ft-lb/min	.0018	hp-sec/min
in-lb/sec	.009	hp-sec/min
in-lb/min	.00015	hp-sec/min

Decimal Equivalents of Fractions

Decimal Equivalent (Inches)		Fraction (Inches)
2-Place	3-Place	
.02	.016	1/64
.03	.031	1/32
.05	.047	3/64
.06	.062	1/16
.08	.078	5/64
.09	.094	3/32
.11	.109	7/64
.12	.125	1/8
.14	.141	9/64
.16	.156	5/32
.17	.172	11/64
.19	.188	3/16
.20	.203	13/64
.22	.219	7/32
.23	.234	15/64
.25	.250	1/4
.27	.266	17/64
.28	.281	9/32
.30	.297	19/64
.31	.312	5/16
.33	.328	21/64
.34	.344	11/32
.36	.359	23/64
.38	.375	3/8

Decimal Equivalent (Inches)		Fraction (Inches)
2-Place	3-Place	
.39	.391	25/64
.41	.406	13/32
.42	.422	27/64
.44	.438	7/16
.45	.453	29/64
.47	.469	15/32
.48	.484	31/64
.50	.500	1/2
.52	.516	33/64
.53	.531	17/32
.55	.547	35/64
.56	.562	9/16
.58	.578	37/64
.59	.594	19/32
.61	.609	39/64
.62	.625	5/8
.64	.641	41/64
.66	.656	21/32
.67	.672	43/64
.69	.688	11/16
.70	.703	45/64
.72	.719	23/32
.73	.734	47/64
.75	.750	3/4

Decimal Equivalent (Inches)		Fraction (Inches)
2-Place	3-Place	
.77	.766	49/64
.78	.781	25/32
.80	.797	51/64
.81	.812	13/16
.83	.828	53/64
.84	.844	27/32
.86	.859	55/64
.88	.875	7/8
.89	.891	57/64
.91	.906	29/32
.92	.922	59/64
.94	.938	15/16
.95	.958	61/64
.97	.969	31/32
.98	.984	63/64
1.00	1.000	1

Application Engineering

Introduction

Information and guidelines provided in the application section are intended for general selection and application of spring set brakes. Unusual operating environments, loading or other undefined factors may affect the proper application of the product. Stearns application services are available to assist in proper selection or to review applications where the specifier may have questions.

A spring set brake is used to stop and hold a rotating shaft. Generally the brake is mounted to an electric motor, but can also be mounted to gear reducers, hoists, machinery or utilize a foot mount kit.

The brake should be located on the high speed shaft of a power transmission system. This permits a brake with the lowest possible torque to be selected for the system.

Spring set disc brakes use friction to stop (dynamic torque) and hold (static torque) a load. Energy of the motor rotor and moving load is converted to thermal energy (heat) in the brake during deceleration. The brakes are power released, spring applied. No electrical current is required to maintain the spring set condition.

The system designer will need to consider the mount surface and match the brake to the load and application. Factors include: brake torque, stopping time, deceleration rate, load weight and speed, location and environment. Brake thermal ratings, electrical requirements and environmental factors are discussed in separate sections.

Electrical Considerations

Solenoid actuated brakes (SAB) are available with standard motor voltages, frequencies and Class B or H coil insulation. Most models can be furnished with either single or dual voltage coils. Coils in most models are field replaceable.

Inrush and holding amperage information is published for the common coil voltages and factory available for other voltages or frequencies. Amperage information for specific coil sizes is provided for selection of wire size and circuit protection at brake installation. Fixed voltage - 50/60 Hz dual frequency coils are available in many models.

All SAB AC coils are single phase and can be wired to either single or three phase motors without modifications. All solenoid coils have a voltage range of +/- 10% of the rated nameplate voltage at the rated frequency. Instantaneous rated voltage must be supplied to the coil to insure proper solenoid pull in and maximum coil cycle rate. The plunger rapidly seats in the solenoid and the

amperage requirements drops to a holding amperage value.

Instantaneous voltage must be supplied to the coil to insure proper solenoid pull-in and maximum coil cycle rate.

Since Stearns SABs require low current to maintain the brake in the released position, the response time to set the brake *can* be affected by EMF voltages generated by the motor windings. It may be necessary to isolate the brake coil from the motor winding.

The solenoid coil cycle rate limits the engagements per minute of a static or holding duty brake. Brake thermal performance, discussed in another section, limits engagements per minute in dynamic applications.

Class B insulation is standard in most SAB models, class H coil insulation is optional and is recommended for environments above 104°F (40°C), or rapid cycling applications.

Armature actuated brakes (AAB) are available in standard DC voltages. Available AC rectification is listed in the catalog section. Wattage information is provided in the catalog pages. Unlike solenoid actuated brakes, armature actuated brakes do not have inrush amperage. Coil and armature reaction time and resulting torque response time information is available. Like SAB, mechanical reaction time depends on typical application factors including load, speed and position.

Electrical response time and profiles are unique to the SAB and AAB. Reaction time requirements should be considered when selecting or interchanging brakes.

All Stearns brake coils are rated for continuous duty and can be energized continually without overheating. The coil heating effect is greatest at coil engagement due to engaging, pull in or inrush amperage.

Temperature limits as established by UL controls standards are:

Class A insulation	221°F (105°C)
Class B insulation	266°F (130°C)
Class H insulation	356°F (180°C).

Types of Applications

In order to simplify the selection of a disc brake, loads can be classified into two categories, non-overhauling and overhauling.

Loads are classified as non overhauling, if (1) no components of the connected equipment or external material undergo a change of height, such as would occur in hoisting, elevating or lowering a load, and (2) there is only rotary motion in a horizontal plane. For example, a loaded conveyor operating in a horizontal plane would be typical of a non-overhauling load.

If the same conveyor were transporting material to a lower level, it would be classified as an overhauling load. The external material or load undergoes a change in height, with the weight of the load attempting to force the conveyor to run faster than its design speed or to overhaul.

Non-overhauling loads require braking torque only to stop the load and will remain at rest due to system friction. Overhauling loads, such as a crane hoist, have two torque requirements. The first requirement is the braking torque required to *stop* the load, and the second requirement is the torque required to *hold* the load at rest. The sum of these requirements is considered when selecting a brake for an overhauling load.

Alignment

Requirements per NEMA:

Permissible ECCENTRICITY of mounting rabbet (AK dimension):

42C to 286TC frames inclusive is 0.004" total indicator reading. 324TC to 505TC frames inclusive is 0.007" total indicator reading.

Face Runout:

42C to 286TC frames inclusive is 0.004" total indicator reading.

If a customer furnishes a face on the machine for brake mounting, the same tolerances apply. Floor mounted brakes must be carefully aligned within 0.005" for concentricity and angular alignment. Use of dowels to insure permanent alignment is recommended.

In offset brake mount locations such as fan covers, cowls or jack shafting, proper mount rigidity and bearing support must be provided. Spring set frictional brakes characteristically have a rapid stop during torque application which may affect the mount surface or contribute to shaft deflection.

Printed installation information is published and available on all Stearns spring set brakes.

Determining Brake Torque

Torque Ratings

Brake torque ratings are normally expressed as nominal static torque. That is, the torque required to begin rotation of the brake from a static, engaged condition. This value is to be distinguished from dynamic torque, which is the retarding torque required to stop a linear, rotating or overhauling load.

As a general rule, a brake's dynamic torque is approximately 80% of the static torque rating of the brake for stopping time up to one second. Longer stopping time will produce additional brake heat and possible fading (reduction) of dynamic torque. The required dynamic torque must be converted to a static torque value before selecting a brake, using the relationship:

$$T_s = \frac{T_d}{0.8}$$

Where, T_s = Static torque, lb-ft

T_d = Dynamic torque, lb-ft

0.8 = Constant
(derating factor)

All Stearns brakes are factory burnished and adjusted to produce no less than rated nominal static torque. Burnishing is the initial wear-in and mating of the rotating friction discs with the stationary metallic friction surfaces of the brake.

Although brakes are factory burnished and adjusted, variations in torque may occur if components are mixed when disassembling and reassembling the brake during installation. Further burnishing may be necessary after installation. Friction material will burnish under normal load conditions. Brakes used as holding only duty require friction material burnishing at or before installation to insure adequate torque.

When friction discs are replaced, the brake must be burnished again in order to produce its rated holding torque.

System Friction

The friction and rolling resistance in a power transmission system is usually neglected when selecting a brake. With the use of anti-friction bearings in the system, friction and rolling resistance is usually low enough to neglect. Friction within the system will assist the brake in stopping the load. If it is desired to consider it, subtract the frictional torque from the braking torque necessary to decelerate and stop the load. Friction and rolling resistance are neglected in the examples presented in this guide.

Non-overhauling Loads

There are two methods for determining brake torque for non-overhauling loads. The first method is to size the brake to the torque of the motor. The second is to select a brake on the basis of the total system or load inertia to be stopped.

Selecting Brake Torque from the Motor Data

Motor full-load torque based on nameplate horsepower and speed can be used to select a brake. This is the most common method of selecting a brake torque rating due to its simplicity.

This method is normally used for simple rotary and linear inertial loads. Brake torque is usually expressed as a percent of the full load torque of

the motor. Generally this figure is not less than 100% of the motor's full load torque. Often a larger service factor is considered. Refer to Selection of Service Factor.

The required brake torque may be calculated from the formula:

$$T_s = \frac{5,252 \times P}{N} \times SF$$

Where, T_s = Static brake torque, lb-ft

P = Motor horsepower, hp

N = Motor full load speed, rpm

SF = Service factor

5,252 = Constant

Match the brake torque to the hp used in the application. When an oversized motor hp has been selected, brake torque based on the motor hp may be excessive for the actual end use.

Nameplate torque represents a nominal static torque. Torque will vary based on combinations of factors including cycle rate, environment, wear, disc burnish and flatness. Spring set brakes provide a rapid stop and hold and are generally not used in repeat positioning applications.

Selection of Service Factor (SF)

A service factor is applied to the basic drive torque calculation. The SF compensates for any tolerance variation, data inaccuracy, unplanned transient torque and potential variations of the friction disc.

When using the basic equation:

$T = (\text{hp} \times 5252) / \text{rpm}$ with non-overhauling loads, a service factor of 1.2 to 1.4 is typical. Overhauling loads with unknown factors such as reductions may use a service factor of 1.4 to 1.8.

Spring set brakes combined with variable frequency drives use service factors ranging from 1.0 to 2.0 (2.0 for holding duty only) depending on the system design. These holding duty brakes must be wired to a separate dedicated power supply.

Occasionally, a brake with a torque rating less than the motor full load torque or with a service factor less than 1.0 is selected. These holding or soft stop applications must be evaluated by the end user or system designer to insure adequate sizing and thermal capacity.

Typically a brake rated 125% of the motor full load torque, or with a 1.25 service factor, provides a stop in approximately the same time as that required for the motor to accelerate the load to full load speed.

Occasionally a motor is oversized or undersized for the load or application. In these situations, the load inertia and desired stopping time calculations should be used rather than relying on the service factor method alone.

Service factor selection can be based on motor performance curves. Motor rotor and load inertia should be considered in this selection process. Depending on the motor design (NEMA A, B, C and D), rpm and horsepower, the maximum torque is either the starting or breakdown torque. A NEMA design B, 3 phase, squirrel cage design motor at breakdown torque produces a minimum of 250% the full load torque. A service factor of 2.5 would be selected. Typical service factors depending on NEMA motor design are: NEMA design A or B: 1.75 to 3.0, NEMA design C: 1.75 to 3.0 and NEMA design D: not less than 2.75.

A brake with an excessive service factor may result in system component damage, an unreasonably rapid stop or loss of load control. A SF above 2.0 is not recommended without evaluation by the end user or system designer.

Example 1: Select brake torque from motor horsepower and speed.

Given: Motor power (P) - 5 hp

Motor speed (N) - 1,750 rpm

Service factor (SF) - 1.4

$$T = \frac{5,252 \times P}{N} \times SF$$

$$= \frac{5,252 \times 5}{1,750} \times 1.4$$

$$T = 21 \text{ lb-ft}$$

A brake having a standard rating of 25 lb-ft nominal static torque would be selected.

Example 2 illustrates selection of a brake to provide proper static torque to hold a load if dynamic braking were used to stop the load.

Example 2: Select a brake to hold a load in position after some other method, such as dynamic braking of the motor, has stopped all rotation.

Given: Weight of load (W) - 5 lb

Drum radius (R) - 2 ft

Service factor (SF) - 1.4

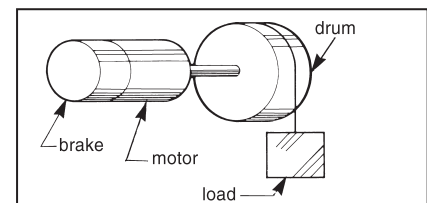

The static holding torque is determined by the weight of the load applied at the drum radius. A service factor is applied to ensure sufficient holding torque is available in the brake.

$$T_s = F \times R \times SF$$

$$= 5 \times 2 \times 1.4$$

$$T_s = 14 \text{ lb-ft}$$

Sizing the Brake to the Inertial Load

For applications where the load data is known, where high inertial loads exist, or where a stop in a specified time or distance is required, the brake should be selected on the basis of the total inertia to be retarded. The total system inertia, reflected to the brake shaft speed, would be:

$$Wk_T^2 = Wk_B^2 + Wk_M^2 + Wk_L^2$$

Where: Wk_T^2 = Total inertia reflected to the brake, lb-ft²

Wk_B^2 = Inertia of brake, lb-ft²

Wk_M^2 = Inertia of motor rotor, lb-ft²

Wk_L^2 = Equivalent inertia of load reflected to brake shaft, lb-ft²

Other significant system inertias, including speed reducers, shafting, pulleys and drums, should also be considered in determining the total inertia the brake would stop.

If any component in the system has a rotational speed different than the rotational speed of the brake, or any linear moving loads are present, such as a conveyor load, their equivalent inertia in terms of rotary inertia at the brake rotational speed must be determined. The following formulas are applicable:

Rotary Motion:

$$\text{Equivalent } Wk_B^2 = Wk_L^2 \left(\frac{N_L}{N_B} \right)^2$$

Where,

Equivalent Wk_B^2 = Inertia of rotating load reflected to brake shaft, lb-ft²

Wk_L^2 = Inertia of rotating load, lb-ft²

N_L = Shaft speed at load, rpm

N_B = Shaft speed at brake, rpm

Horizontal Linear Motion

$$\text{Equivalent } Wk_W^2 = W \left(\frac{V}{2\pi N_B} \right)^2$$

Where,

Equivalent Wk_W^2 = Equivalent inertia of linear moving load reflected to brake shaft, lb-ft²

W = Weight of linear moving load, lb

V = Linear velocity of load, ft/min

N_B = Shaft speed at brake, rpm

Once the total system inertia is calculated, the required average dynamic braking torque can be calculated using the formula:

$$T_d = \frac{Wk_T^2 \times N_B}{308 \times t}$$

Where, T_d = Average dynamic braking torque, lb-ft

Wk_T^2 = Total inertia reflected to brake, lb-ft²

N_B = Shaft speed at brake, rpm

t = Desired stopping time, sec

308 = Constant

The calculated dynamic torque is converted to the static torque rating using the relationship:

$$T_s = \frac{T_d}{0.8}$$

Where, T_s = Brake static torque, lb-ft

T_d = System dynamic torque, lb-ft

Examples 3, 4, 5 and 6 illustrate how brake torque is determined for non-overhauling loads where rotary or horizontal linear motion is to be stopped.

Example 3: Select a brake to stop a rotating flywheel in a specified time.

Given, Motor speed (N_M) - 1,750 rpm

Motor inertia (Wk_M^2) - 0.075 lb-ft²

Flywheel inertia (Wk_{FW}^2) - 4 lb-ft²

Brake inertia (Wk_B^2) - 0.042 lb-ft²

Required stopping time (t) - 1 sec

First determine the total inertia to be stopped,

$$Wk_T^2 = Wk_M^2 + Wk_{FW}^2 + Wk_B^2$$

$$= 0.075 + 4 + 0.042$$

$$Wk_T^2 = 4.117 \text{ lb-ft}^2$$

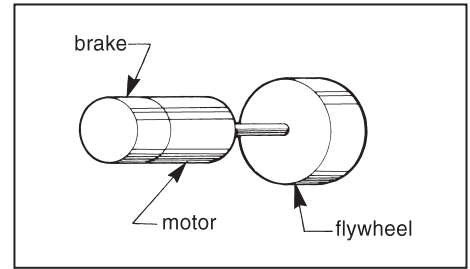

The dynamic braking torque required to stop the total inertia in 1 second is,

$$T_d = \frac{Wk_T^2 \times N_{BM}}{308 \times t}$$

$$= \frac{4.117 \times 1,750}{308 \times 1}$$

$$T_d = 23.4 \text{ lb-ft}$$

Converting T_d to static torque

$$T_s = \frac{T_d}{0.8}$$

$$= \frac{23.4}{0.8}$$

$$T_s = 29.3 \text{ lb-ft}$$

A brake having a standard static torque rating of 35 lb-ft would be selected. Since a brake with more torque than necessary to stop the flywheel in 1 second is selected, the stopping time would be,

$$t = \frac{Wk_T^2 \times N_{BM}}{308 \times T_d}$$

$$= \frac{Wk_T^2 \times N_{BM}}{308 \times (0.8 T_s)}$$

$$= \frac{4.117 \times 1,750}{308 \times (0.8 \times 35)}$$

$$t = 0.84 \text{ sec}$$

See section on stopping time and thermal information.

Example 4: Select a brake to stop a rotating flywheel, driven through a gear reducer, in a specified time.

Given: Motor speed (N_M) - 1,800 rpm

Motor inertia (Wk_M^2) - 0.075 lb-ft²

Gear reduction (GR) - 20:1

Gear reducer inertia at high speed shaft (Wk_{GR}^2) - 0.025 lb-ft²

Flywheel inertia (Wk_{FW}^2) - 20 lb-ft²

Required stopping time (t) - 0.25 sec

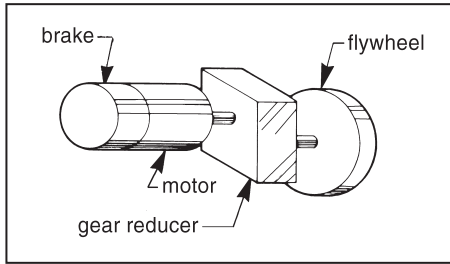

First, determine rotating speed of flywheel (N_{FW})

$$N_{FW} = \frac{N_{BM}}{GR}$$

$$= \frac{1,800}{20}$$

$$N_{FW} = 90 \text{ rpm}$$

Next, the inertia of the flywheel must be reflected back to the motor brake shaft.

$$Wk_b^2 = Wk_{FW}^2 \left(\frac{N_{FW}}{N_M} \right)^2$$

$$= 20 \left(\frac{90}{1,800} \right)^2$$

$$Wk_b^2 = 0.05 \text{ lb-ft}^2$$

Determining the total Wk^2 ,

$$Wk_T^2 = Wk_M^2 + Wk_{GR}^2 + Wk_b^2$$

$$= 0.075 + 0.025 + 0.05$$

$$Wk_T^2 = 0.15 \text{ lb-ft}^2$$

The required dynamic torque to stop the flywheel in 0.25 seconds can now be determined.

$$T_d = \frac{Wk_T^2 \times N_{BM}}{308 \times t}$$

$$T_d = \frac{0.15 \times 1,800}{308 \times 0.25}$$

$$T_d = 3.5 \text{ lb-ft}$$

Converting dynamic torque to static torque,

$$T_s = \frac{T_d}{0.8}$$

$$= \frac{3.5}{0.8}$$

$$T_s = 4.4 \text{ lb-ft}$$

A brake having a standard static torque rating of 6 lb-ft would be selected. Since a brake with more torque than necessary to stop the flywheel in 0.25 seconds is selected, the stopping time would be,

$$t = \frac{Wk_T^2 \times N_M}{308 \times T_d}$$

$$= \frac{Wk_T^2 \times N_M}{308 \times (0.8 \times T_s)}$$

$$= \frac{0.15 \times 1,800}{308 \times (0.8 \times 6)}$$

$$t = 0.18 \text{ sec}$$

See section on stopping time and thermal information.

Example 5: Select a brake to stop a load on a horizontal belt conveyor in a specified time.

Given:

Conveyor pulley speed (N_p) - 32 rpm

Weight of load (W) - 30 lb

Conveyor pulley and belt inertia (Wk_p^2) - 4.0 lb-ft²

Conveyor pulley diameter (d_p) - 1 ft

Required stopping time (t) - 0.25 sec

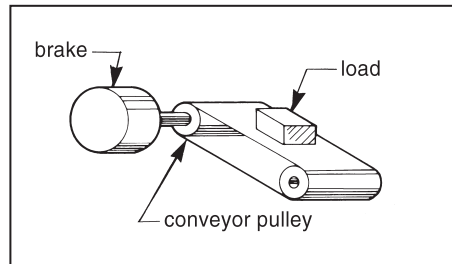

First, convert the rotational pulley speed to linear belt speed (V_B).

$$V_B = \pi d_p N_p$$

$$= \pi \times 1 \times 32$$

$$V_B = 100.5 \text{ ft/min}$$

Next, determine inertia of load.

$$Wk_W^2 = W \left(\frac{V_B}{2\pi \times N_p} \right)^2$$

$$= 30 \left(\frac{100.5}{2\pi \times 32} \right)^2$$

$$Wk_W^2 = 7.5 \text{ ft-lb}^2$$

Then, determine total inertial load.

$$Wk_T^2 = Wk_W^2 + Wk_p^2$$

$$= 7.5 + 4.0$$

$$Wk_T^2 = 11.5 \text{ lb-ft}^2$$

The required dynamic torque to stop the conveyor load in 0.25 seconds can now be determined.

$$T_d = \frac{Wk_T^2 \times N_p}{308 \times t}$$

$$T_d = \frac{11.5 \times 32}{308 \times 0.25}$$

$$T_d = 4.8 \text{ lb-ft}$$

Converting dynamic torque to static torque,

$$T_s = \frac{T_d}{0.8}$$

$$= \frac{4.8}{0.8}$$

$$T_s = 6 \text{ lb-ft}$$

A brake having a standard static torque rating of 6 lb-ft would be selected. See thermal information.

Example 6: Select a brake to stop a trolley crane and its load in a specified time. Brake mounted on wheel axle.

Given:

Weight of crane (W_c) - 2,000 lb

Weight of load (W_L) - 100 lb

Trolley velocity (v) - 3 ft/sec or 180 ft/min

Radius of trolley wheel (r) - 0.75 ft

Required stopping time (t) - 2 sec

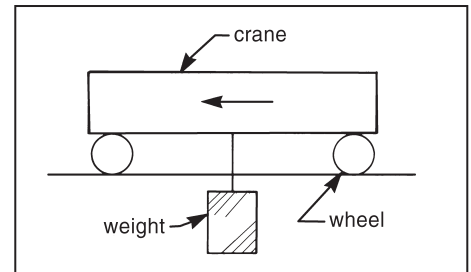

The dynamic braking torque required to stop the trolley crane and load can be determined by one of two methods. The first method is to determine the equivalent inertia of the linearly moving crane and load, then calculate the dynamic braking torque. The second method is to determine the dynamic braking torque directly.

Using the first method, the total weight to be stopped is determined first.

$$W_T = W_L + W_C$$

$$= 100 + 2,000$$

$$W_T = 2,100 \text{ lb}$$

Next, the rotational speed of the axle (N_B) is calculated.

$$N_B = \frac{V}{2\pi r}$$

$$= \frac{180}{2 \times \pi \times 0.75}$$

$$N_B = 38.2 \text{ rpm}$$

Then, the equivalent inertia of the linearly moving crane and load is determined.

$$Wk_f^2 = W_T \left(\frac{V}{2\pi N_B} \right)^2$$

$$= 2,100 \left(\frac{180}{2\pi \times 38.2} \right)^2$$

$$Wk_f^2 = 1,181 \text{ lb-ft}^2$$

Finally, the dynamic braking torque required to stop the total inertia in 2 seconds is,

$$T_d = \frac{Wk_f^2 \times N_B}{308 \times t}$$

$$= \frac{1,181 \times 38.2}{308 \times 2}$$

$$T_d = 73 \text{ lb-ft}$$

Using the second method, the dynamic braking torque required to stop the crane and load in 2 seconds can be calculated directly using the formula,

$$T_d = \frac{W_T v}{gt} \times r$$

Where, T_d = Average dynamic braking torque, lb-ft

W_T = Total weight of linear moving load, lb

v = Linear velocity of load, ft/sec

g = Gravitational acceleration constant, 32.2 ft/sec²

t = Desired stopping time, sec

r = Length of the moment arm (wheel radius), ft

or, for this example,

$$T_d = \frac{2,100 \times 3}{32.2 \times 2} \times 0.75$$

$$T_d = 73 \text{ lb-ft}$$

For both methods above, the required dynamic braking torque is converted to static torque,

$$T_s = \frac{T_d}{0.8}$$

$$= \frac{73}{0.8}$$

$$T_s = 91 \text{ lb-ft}$$

A smaller brake could be mounted on the high speed shaft in place of the higher torque on the low speed shaft.

A brake having a standard static torque rating of 105 lb-ft is selected. Since a brake with more torque than necessary to stop the load in 2 seconds is selected, the stopping time would be,

$$T = \frac{W_T v}{g T_d} \times r$$

$$= \frac{W_T v}{g \times (0.8 \times T_s)} \times r$$

$$= \frac{2,100 \times 3}{32.2 \times (0.8 \times 105)} \times 0.75$$

$$t = 1.8 \text{ sec}$$

See section on stopping time and cycle rates, thermal selection. Stops should be under 2 seconds. Longer stops require application test.

Overhauling Loads

Applications with a descending load, such as power lowered crane, hoist or elevator loads, require a brake with sufficient torque to both *stop* the load, and *hold* it at rest. Overhauling loads having been brought to rest still invite motion of the load due to the effect of gravity. Therefore, brake torque must be larger than the overhauling torque in order to stop and hold the load. If brake torque is equal to or less than the overhauling torque, there is no net torque available for stopping a descending load.

First, the total system inertia reflected to the brake shaft speed must be calculated.

Second, the average dynamic torque required to decelerate the descending load in the required time is calculated with the formula:

$$T_d = \frac{Wk_f^2 \times N_B}{308 \times t}$$

Where, T_d = Average dynamic braking torque, lb-ft

Wk_f^2 = Total inertia reflected to brake, lb-ft²

N_B = Shaft speed at brake, rpm. Consider motor slip when descending.

t = Desired stopping time, sec

Third, the overhauling torque reflected to the brake shaft is determined by the formula:

$$T_o = W \times R \times \frac{N_L}{N_B}$$

Where, T_o = Overhauling dynamic torque of load reflected to brake shaft, lb-ft

W = Weight of overhauling load, lb

R = Radius of hoist or elevator drum, ft

N_L = Rotating speed of drum, rpm

N_B = Rotating speed at brake, rpm

Or alternately, the dynamic torque to overcome the overhauling load can be calculated with the formula:

$$T_o = \frac{0.158 \times W \times V}{N_B}$$

Where, T_o = Overhauling dynamic torque of load reflected to brake shaft, lb-ft

W = Weight of overhauling load, lb

V = Linear velocity of descending load, ft/min

N_B = Shaft speed at brake, rpm

0.158 = Constant

Next, the total dynamic torque required to stop and hold the overhauling load is the sum of the two calculated dynamic torques:

$$T_t = T_d + T_o$$

Finally, the dynamic torque must be converted to static brake torque to select a brake:

$$T_s = \frac{T_d}{0.8}$$

Where, T_s = Brake static torque, lb-ft

T_t = System dynamic torque, lb-ft

If the total inertia of the system and overhauling load cannot be accurately determined, a brake rated at 180% the motor full load torque should be selected. Refer to selection of service factor. The motor starting torque may permit a heavier than rated load to be lifted; the brake must stop the load when descending.

Examples 7, 8 and 9 illustrate how brake torque would be determined for overhauling loads. In these examples brakes are selected using the system data rather than sizing them to the motor. Refer to the section on thermal calculations to determine cycle rate.

Consider motor slip in calculation. An 1800 rpm motor with 10% slip would operate at 1,620 rpm when the load is ascending and 1,980 rpm when descending. Motor rpm, armature inertia and load position will affect stop time. Brakes on overhauling loads should be wired through a dedicated relay.

Example 7: Select a brake to stop an overhauling load in a specified time.

Given: Cable speed (V) - 667 ft/min
 Weight of load (W) - 100 lb
 Drum diameter (D) - 0.25 ft
 Drum inertia (Wk_d^2) - 5 lb-ft²
 Required stopping time (t) - 1 sec

First, determine brakemotor shaft speed (N_B).

$$N_B = \frac{V}{\pi D}$$

$$= \frac{667}{\pi \times 0.25}$$

$$N_B = 849 \text{ rpm}$$

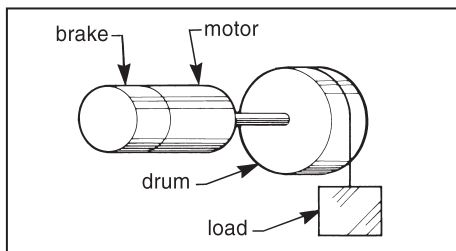

Then, determine the equivalent inertia of the overhauling load.

$$Wk_f^2 = W \left(\frac{V}{2\pi N_B} \right)^2$$

$$= 100 \left(\frac{667}{2\pi \times 849} \right)^2$$

$$Wk_f^2 = 1.56 \text{ lb-ft}^2$$

Therefore, the total inertia at the brake is,

$$Wk_f^2 = Wk_d^2 + Wk_f^2$$

$$= 5 + 1.56$$

$$Wk_f^2 = 6.56 \text{ lb-ft}^2$$

Now, the dynamic torque required to decelerate the load and drum in the required time is calculated.

$$T_d = Wk_f^2 \times N_B$$

$$= \frac{6.56 \times 850}{308 \times 1}$$

$$T_d = 18.1 \text{ lb-ft}$$

Next, calculate the dynamic torque required to overcome the overhauling load.

$$T_O = W \times R$$

$$= 100 \times \frac{0.25}{2}$$

$$T_O = 12.5 \text{ lb-ft}$$

The total dynamic torque to stop and hold the overhauling load is the sum of the two calculated dynamic torques.

$$T_t = T_d + T_O$$

$$= 18.1 + 12.5$$

$$T_t = 30.6 \text{ lb-ft}$$

Dynamic torque is then converted to static torque.

$$T_s = \frac{T_t}{0.8}$$

$$= \frac{30.6}{0.8}$$

$$T_s = 38.3 \text{ lb-ft}$$

A brake having a standard torque rating of 50 lb-ft is selected based on expected stop time. Since a brake with more torque than necessary to stop the load in 1 second is selected, the stopping time would be,

$$t = \frac{Wk_f^2 \times N}{308 \times T_d}$$

where,

$$T_s = \frac{T_t}{0.8}$$

$$= \frac{T_d + T_O}{0.8}$$

or,

$$T_d = 0.8T_s - T_O$$

$$= (0.8)(50) - 12.5$$

$$T_d = 27.5 \text{ lb-ft}$$

therefore,

$$t = \frac{6.56 \times 850}{308 \times 27.5}$$

$$t = 0.7 \text{ sec}$$

Wire the brake through a dedicated relay on overhauling loads where stop time or distance is critical. See section on stopping time.

Example 8: Select a brake to stop an overhauling load driven through gear reducer in a specified time.

Given: Motor speed (N_M) - 1,150 rpm
 Motor inertia (Wk_M^2) - 0.65 lb-ft²
 Gear reduction (GR) - 300:1
 Drum diameter (D) - 1.58 ft
 Weight of load (W) - 4,940 lb
 Drum inertia (Wk_d^2) - 600 lb-ft²
 Required stopping time (t) - 0.5 sec

First, calculate all inertial loads reflected to the brake motor shaft.

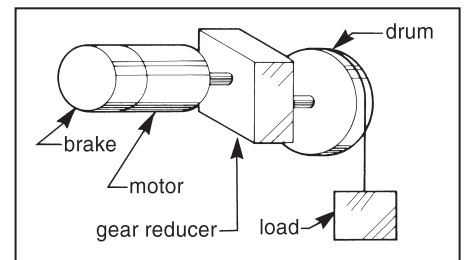

The rotational speed of the drum is,

$$N_D = \frac{N_M}{GR}$$

$$= \frac{1,150}{300}$$

$$N_D = 3.83 \text{ rpm}$$

From this, the cable speed can be determined.

$$V = N_D \times \pi D$$

$$= 3.83 \times \pi \times 1.58$$

$$V = 19.0 \text{ ft/min}$$

The equivalent inertia of the load reflected to the brake motor shaft is,

$$Wk_f^2 = W \left(\frac{V}{2\pi N_{BM}} \right)^2$$

$$= 4,940 \left(\frac{19.0}{2\pi \times 1,150} \right)^2$$

$$Wk_f^2 = 0.034 \text{ lb-ft}^2$$

The equivalent inertia of the drum at the brake motor shaft speed is,

$$Wk_d^2 = Wk_D^2 \left(\frac{N_D}{N_{BM}} \right)^2$$

$$= 600 \left(\frac{3.83}{1,150} \right)^2$$

Finally, the total inertia the brake will retard is,

$$Wk_T^2 = Wk_M^2 + Wk_I^2 + Wk_d^2$$

$$Wk_T^2 = 0.0067 \text{ lb-ft}^2$$

$$Wk_T^2 = 0.691 \text{ lb-ft}^2$$

The dynamic torque required to decelerate the total inertia is,

$$T_d = \frac{Wk_T^2 \times N_{BM}}{308 \times t}$$

$$= \frac{0.691 \times 1,150}{308 \times 0.5}$$

$$T_d = 5.16 \text{ lb-ft}^2$$

Now, calculate the dynamic torque to overcome the overhauling load.

$$T_o = W \times R = W \times \frac{1}{2} D$$

$$= 4,940 \times \frac{1.58}{2}$$

$$T_o = 3,903 \text{ lb-ft}$$

Which reflected to the brake motor shaft becomes,

$$T_m = \frac{T_o}{GR}$$

$$= \frac{3,903}{300}$$

$$T_m = 13.0 \text{ lb-ft}$$

Then, the total dynamic torque to stop and hold the overhauling load is the sum of the two calculated dynamic torques.

$$T_t = T_d + T_m$$

$$= 5.16 + 13.0$$

$$T_t = 18.16 \text{ lb-ft}$$

Dynamic torque is then converted to static torque.

$$T_s = \frac{T_t}{0.8}$$

$$= \frac{18.16}{0.8}$$

$$T_s = 22.7 \text{ lb-ft}$$

A brake having a standard torque rating of 25 lb-ft is selected.

Example 9: Select a brake to stop and hold a load on an inclined plane (skip hoist).

Given: Motor data
Power (P) - 7½ hp
Speed (N_M) - 1,165 rpm
Rotor inertia (Wk_M²) - 1.4 lb-ft²

Gear reducer data:

Reduction (G_R) - 110:1
Inertia at input shaft (Wk_R²) - 0.2 lb-ft²

Drum data

Diameter (D_D) - 1.5 ft
Inertia (Wk_D²) - 75 lb-ft²

Pulley data

Diameter (D_P) - 1.5 ft
Inertia (Wk_P²) - 20 lb-ft²
Bucket weight (W_B) - 700 lb
Maximum weight of load (W_L) - 4,000 lb
Slope of track (B) - 52.7°

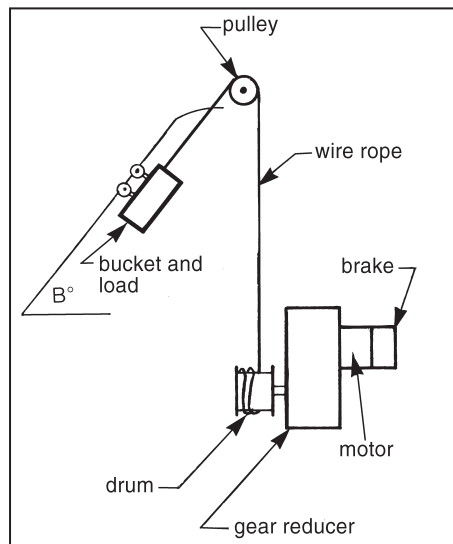

Required stopping time (t) - 1 sec

The bucket is full when ascending the track and is empty when descending. When selecting a brake the most severe condition would be a fully loaded bucket backed down the hoist track. In normal operation the descending bucket would be empty. In this example, the brake is selected for the most severe condition.

The total torque to stop and hold the bucket and load when descending is the sum of (a) the torque to decelerate the total inertia and (b) the torque required to hold the loaded bucket.

First, calculate all inertial loads reflected to the brake motor shaft. The rotational speed of the drum is:

$$N_D = \frac{N_M}{GR}$$

$$= \frac{1,165}{110}$$

$$N_D = 10.6 \text{ rpm}$$

From this the cable speed can be determined:

$$V = N_D \times \pi D_D$$

$$= 10.6 \times \pi \times 1.5$$

$$V = 50 \text{ ft/min}$$

The equivalent inertia of the loaded bucket reflected to the brake motor shaft is,

$$Wk_I^2 = W \left(\frac{V}{2\pi N_M} \right)^2$$

$$= 4,700 \left(\frac{50}{2\pi \times 1,165} \right)^2$$

$$Wk_I^2 = 0.219 \text{ lb-ft}^2$$

Next, the inertia of the pulley and drum are reflected to the brake motor shaft speed so the total inertia at the brake can be determined.

Since the diameters of the pulley and drum are the same, 1.5 ft, their rotational speeds would be the same, 10.6 rpm.

The inertia of the pulley reflected to the brake motor shaft is,

$$Wk_P^2 = Wk_P^2 \left(\frac{N_D}{N_M} \right)^2 = Wk_P^2 \left(\frac{1}{GR} \right)^2$$

$$= 20 \times \left(\frac{1}{110} \right)^2$$

$$Wk_P^2 = 0.0017 \text{ lb-ft}^2$$

The inertia of the drum reflected to the brake motor shaft is,

$$Wk_D^2 = Wk_D^2 \left(\frac{N_D}{N_M} \right)^2 = Wk_D^2 \left(\frac{1}{GR} \right)^2$$

$$= 75 \times \left(\frac{1}{110} \right)^2$$

$$Wk_D^2 = 0.0062 \text{ lb-ft}^2$$

The total inertia to be stopped is,

$$Wk_T^2 = Wk_I^2 + Wk_P^2 + Wk_D^2 + Wk_R^2 + Wk_M^2$$

$$= 0.219 + 0.0017 + 0.0062 + 0.2 + 1.4$$

$$Wk_T^2 = 1.827 \text{ lb-ft}^2$$

Then, the dynamic torque required to bring the descending bucket and load to rest is,

$$T_d = \frac{Wk_T^2 \times N_M}{308 \times T_d}$$

$$T_d = \frac{1.827 \times 1,165}{308 \times 1}$$

The additional dynamic torque required to hold the overhauling load would be determined by the unbalanced component of the force acting along the plane of the hoist track, $W_T \sin B$, and the length of the moment arm which is the drum radius (R_D). $W_T \sin B$ is the force necessary to retard downward motion of the loaded hoist bucket.

$$\begin{aligned} T_O &= W_T \sin B \times R_D \\ &= W_T \sin B \times \frac{1}{2} D_D \\ &= 4,700 \times \sin 52.7^\circ \times \frac{1}{2} (1.5) \\ &= 4,700 \times 0.7955 \times 0.75 \\ T_O &= 2,804 \text{ lb-ft} \end{aligned}$$

Which reflected to the brake motor shaft becomes,

$$\begin{aligned} T_m &= \frac{T_O}{GR} \\ &= \frac{2,804}{110} \\ T_m &= 25.5 \text{ lb-ft} \end{aligned}$$

Then, the total dynamic torque to stop and hold the descending bucket and load is the sum of the two calculated dynamic torques.

$$\begin{aligned} T_t &= T_d + T_m \\ &= 6.9 + 25.5 \\ T_t &= 32.4 \text{ lb-ft} \end{aligned}$$

Converting to static torque,

$$\begin{aligned} T_s &= \frac{T_t}{0.8} \\ &= \frac{32.4}{0.8} \\ T_s &= 40.5 \text{ lb-ft} \end{aligned}$$

A brake having a standard torque rating of 50 lb-ft is selected. Since a brake with more torque than necessary to stop the load in 1 second is selected, the stopping time would be,

$$t = \frac{Wk_f^2 \times N_B}{308 \times T_d}$$

$$\begin{aligned} \text{Where, } T_s &= \frac{T_t}{0.8} \\ &= \frac{T_d + T_m}{0.8} \end{aligned}$$

$$\begin{aligned} \text{or, } T_d &= 0.8 T_s - T_m \\ &= (0.8)(50) - 25.5 \end{aligned}$$

$$T_d = 14.5 \text{ lb-ft}$$

therefore,

$$\begin{aligned} t &= \frac{1,827 \times 1,165}{308 \times 14.5} \\ t &= 0.48 \text{ sec} \end{aligned}$$

See section on stopping time.

Stopping Time & Deceleration Rate

In the formulas used to determine dynamic torque, stopping time or "t" in seconds is a desired or assumed value selected on the requirements of the application. For optimum brake performance, a stopping or braking time of 1 second or less is desirable. Stop times between 2 and 3 seconds require test. *A brake of insufficient torque rating will lengthen the stopping time. This may result in overheating of the brake to a point where torque falls appreciably. The friction material could carbonize, glaze, or fail.*

After determining the braking torque required by a system, it may be necessary to recalculate the stopping time based on the actual brake size selected to insure that stopping time falls within the 0 to 2 second range. Any formula, where the stopping time is a variable, may be rewritten to solve for the new stopping time. For instance, the dynamic torque equation may be transposed as follows:

$$\begin{aligned} T_d &= \frac{Wk_f^2 \times N_B}{308 \times t} \\ \text{or, } t &= \frac{Wk_f^2 \times N_B}{308 \times (0.8 \times T_s)} \end{aligned}$$

Where, t = Stopping time, sec

Wk_f^2 = Total inertia reflected to brake, lb-ft²

N_B = Shaft speed at brake, rpm

T_s = Nominal static torque rating of brake, lb-ft

T_d = Dynamic braking torque (0.8 x T_s), lb-ft

0.8 = Constant (derating factor)

308 = Constant

Brakes are rated in static torque. This value is converted to dynamic torque, as done in the above equation, when stopping time is calculated. That is,

$$T_d = 0.8 \times T_s$$

Where, T_d = Dynamic braking torque, lb-ft

T_s = Nominal static torque rating of brake, lb-ft

The approximate number of revolutions the brake shaft makes when stopping is:

$$\text{Revolutions to stop} = \frac{t \times N_B}{120}$$

Where, t = Stopping time, sec

N_B = Shaft speed at brake, rpm

120 = Constant

The average rate of deceleration when braking a linearly moving load to rest can be calculated using the stopping time determined by the above formula and the initial linear velocity of the load.

$$a = \frac{V_i}{t}$$

Where, a = Deceleration, ft/sec²

V_i = Initial linear velocity of load, ft/sec

t = Stopping time, sec

RPM Considerations

The maximum allowable rotational speed of the brake should not be exceeded in braking. Maximum brake rpm as listed in the catalog is intended to limit stopping time to 2 seconds or less and insure friction disc stability. Brakes are not dynamically balanced because of the low brake inertia.

Determining Required Thermal Capacity

Thermal Ratings

When a brake stops a load, it converts mechanical energy to thermal energy or heat. The heat is absorbed by components of the brake. This heat is then dissipated by the brake. The ability of a given brake to absorb and dissipate heat without exceeding temperature limitations is known as thermal capacity.

There are two categories of thermal capacity for a brake. The first is the *maximum* energy the brake can absorb in one stop, generally referred to as a "crash" or "emergency" stop. The second is the heat dissipation capability of the brake when it is cycled frequently. *To achieve optimum brake performance, the thermal rating should not be exceeded. They are specified for a predetermined maximum temperature rise of the brake friction material.*

The ability of a brake to absorb and dissipate heat is determined by many factors, including the design of the brake, the ambient temperature, brake enclosure, position of the brake, the surface that the brake is mounted to, and the altitude.

The rating for a given brake is the maximum allowable. Longer brake life results when the brake has more thermal capacity than a power transmission requires. Much shorter life or brake failure will result when the thermal capacity rating is exceeded. Ratings are determined at an ambient temperature of 72°F (22°C), with the brake in a horizontal position, with a stopping time of 1 second or less, and with no external heat source such as a motor.

Ambient temperature will limit the thermal capacity of a brake. Temperatures above 72°F (22°C) require derating of the thermal capacity rating. For example, at 150°F, thermal capacity is reduced approximately 30% (see Derating Thermal Capacity Chart).

CHART: Derating Thermal Capacity

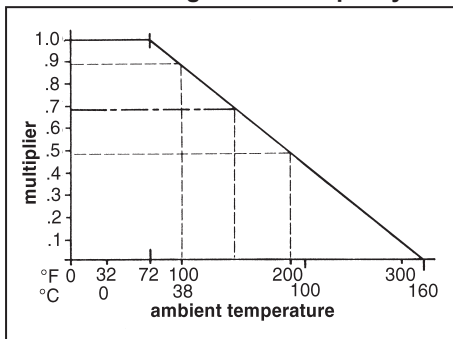

A temperature range of 20°F (-7°C) to 104°F (40°C) is acceptable in most brake applications. Above 104°F also consider Class H coil insulation.

Thermal capacity ratings are determined with enclosures on the brake. Other customer furnished covers or cowls may affect a brake's thermal capacity. The effect on thermal capacity should be evaluated. In some cases, thermal capacity may be increased by use of air or liquid cooling. However, provisions must be made to prevent contaminating the brake internally.

Brakes with brass stationary discs are derated 25%.

The mounting position of a brake will also affect thermal capacity. The specified ratings are for brakes mounted in a horizontal position with the solenoid plunger above the solenoid. For brakes mounted in a vertical position, or 15° or more from horizontal, the thermal capacity decreases due to friction disc drag. Brakes are modified for vertical operation to minimize the drag. 2- and 3- disc brakes are derated 25%, 4-disc brakes are derated 33%. 4- and 5-disc brakes are not recommended for vertical use.

Thermal capacity ratings are established without external sources of heat increasing the brake temperature. The surface that a brake is mounted to, such as an electric

motor or gear reducer, will limit the heat dissipation capability or thermal capacity of a brake. These sources of heat should be evaluated when determining the thermal requirements of the system for which the brake is selected.

High altitudes may also affect a brake's thermal capacity. Stearns brakes will operate to 10,000 ft above sea level at 72°F (22°C) ambient temperature. At 104°F (40°C) ambient temperature, altitude and temperature adjustments occur. Refer to NEMA MG1-1993 section 14 for additional information.

CHART: Altitude & Thermal Capacity

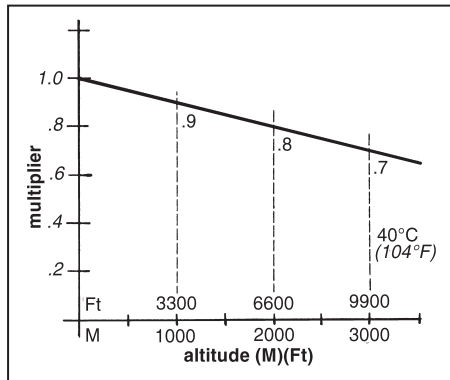

Maximum Energy Absorption

The thermal capacity of a brake is limited by the maximum energy it can absorb in one stop. This factor is important when stopping extremely high inertial loads at infrequent intervals. Such use of a brake requires extensive cooling time before it can be operated again.

The energy a brake is required to absorb in one stop by a given power transmission system is determined by the formulas below. *The calculated energy of the system should not exceed the maximum kinetic energy rating of the brake. System energy exceeding the brake's maximum rating may result in overheating of the brake to a point where torque falls appreciably. The friction material of the brake could glaze, carbonize or fail.*

In the case of linear loads, the energy that the brake must absorb is kinetic energy. It is determined by the formula:

$$KE_l = \frac{Wv^2}{2g}$$

KE_l = Kinetic energy of linear moving load, lb-ft

W = Weight of load, lb

v = Linear velocity of load, ft/sec

g = Gravitational acceleration constant, 32.2 ft/sec²

In the case of rotational loads, the energy that the brake must absorb is also kinetic energy. It is determined by the formula:

$$KE_r = \frac{Wk_f^2 \times N_B^2}{5875}$$

Where, KE_r = Kinetic energy of linear load, lb-ft

Wk_f² = Inertia of the rotating load reflected to brake shaft, lb-ft²

N_B = Shaft speed at brake, rpm

5875 = Constant

In the case of overhauling loads, both the kinetic energy of the linear and rotating loads and the potential energy transformed into kinetic energy by the change in height or position must be considered when determining the total energy that the brake must absorb. The potential energy transformed to kinetic energy is determined by the formula:

$$PE = W_s$$

Where, PE = Change in potential energy, ft-lb

W = Weight of overhauling load, lb

s = Distance load travels, ft

Thus, the total energy to be absorbed by a brake stopping an overhauling load is:

$$E_t = KE_l + KE_r + PE$$

Example 10 illustrates how energy absorption for Example 8 would be determined for one stop.

Example 10: Determine the total energy absorbed by a brake in one stop.

In Example 8, the calculation for total energy to be absorbed would be as follows.

First, calculate the kinetic energy of the linear load. The load weight was 4,940 lb and the velocity is 19 ft/min or 0.317 ft/sec. The kinetic energy is:

$$KE_l = \frac{Wv^2}{2g} = \frac{4,940 \times 0.317^2}{2 \times 32.2}$$

$$KE_l = 7.71 \text{ ft-lb}$$

Next, calculate the kinetic energy for the rotational load. The motor inertia is 0.65 lb-ft² and the drum inertia reflected to the brake shaft speed is 0.0067 lb-ft². The total rotational inertia at the brake motor shaft is,

$$\begin{aligned} Wk_r^2 &= Wk_m^2 + Wk_d^2 \\ &= 0.65 + 0.0067 \\ Wk_r^2 &= 0.6567 \text{ lb-ft}^2 \end{aligned}$$

And the kinetic energy of the rotating components is,

$$\begin{aligned} KE_r &= \frac{Wk_r^2 \times N_B^2}{5,875} \\ &= \frac{0.6567 \times 1,150^2}{5,875} \end{aligned}$$

$$KE_r = 147.8 \text{ ft-lb}$$

Now, calculate the potential energy converted to kinetic energy due to the change in position of the load while descending. A descending load is the most severe case since potential energy is transformed to kinetic energy that the brake must absorb. A 25 lb-ft brake was selected in Example 8. The 25 lb-ft static torque rating is converted to dynamic torque,

$$\begin{aligned} T_d &= T_s \times 0.8 \\ &= 25 \times 0.8 \\ T_d &= 20 \text{ lb-ft} \end{aligned}$$

Of this torque, 13.0 lb-ft is required to overcome the overhauling load as determined in Example 8. The dynamic torque available to decelerate the load is,

$$\begin{aligned} T_d &= T_t - T_m \\ &= 20 - 13 \\ T_d &= 7 \text{ lb-ft} \end{aligned}$$

The stopping time resulting from this dynamic torque is,

$$\begin{aligned} t &= \frac{Wk_r^2 \times N_M}{308 \times T_d} \\ &= \frac{0.691 \times 1,150}{308 \times 7} \\ t &= 0.369 \text{ sec} \end{aligned}$$

Where, $Wk_r^2 = 0.690 \text{ lb-ft}^2$ is the total

inertia the brake is to retard as determined in Example 8. With the load traveling at 19.0 ft/min or 0.317 ft/sec, the distance it will travel is,

$$\begin{aligned} s &= \frac{1}{2} vt \\ &= \frac{1}{2} \times 0.317 \times 0.369 \\ s &= 0.059 \text{ lb-ft} \end{aligned}$$

Wire the brake through a dedicated relay on overhauling loads where stop time or distance is critical. The potential energy transformed to kinetic energy in this distance would be,

$$\begin{aligned} PE &= W_s \\ &= 4,940 \times 0.059 \\ PE &= 291 \text{ ft-lb} \end{aligned}$$

Thus, the total energy to be absorbed by the brake would be,

$$\begin{aligned} E_T &= KE_r + KE_s + PE \\ &= 7.71 + 147.8 + 291 \\ E_T &= 447 \text{ ft-lb} \end{aligned}$$

The 25 lb-ft brake selected in Example 8 should be capable of absorbing 447 ft-lb of energy. The brake's maximum kinetic energy absorption rating should exceed this value.

Motor slip and test loads (150% of load) should be considered both in sizing and thermal calculations.

Brakes overheated in testing will require inspection before using in the standard application.

Heat Dissipation in Cyclic Applications

In general, a brake will repetitively stop a load at the duty cycle that a standard electric motor can repetitively start the load. A brake's thermal capacity is based upon the heat it can absorb and dissipate while cycling. The thermal capacity ratings for brakes are listed in the specification tables for specific brake models.

The energy that a brake is required to absorb and dissipate by a given power transmission system is determined from the total inertia of the load and system, the rotating or linear speed of the load, and the number of times the load is to be stopped in a given time period. The rate of energy dissipation is expressed in horsepower seconds per minute (hp-sec/min). Other common units for energy rates, such as foot pounds per second (ft-lb/sec), can be converted to hp-sec/min using the conversion factors given in the technical data section.

Refer to the Thermal Capacity Chart for use above 104°F (40°C) ambient temperature.

For applications demanding optimum brake performance, such as high inertial loads and frequent stops, the rate of energy dissipation required by the system is determined using the following formulas. *The calculated rate of energy dissipation should not exceed the thermal capacity of the brake. Thermal dissipation*

requirements exceeding the brake's rating may result in overheating of the brake to a point where torque falls appreciably. The friction material of the brake could glaze, carbonize or fail.

For rotating or linear loads, the rate at which a brake is required to absorb and dissipate heat when frequently cycled is determined by the relationship:

$$TC = \frac{Wk_r^2 \times N_B^2 \times n}{3.2 \times 10^6}$$

Where, TC = Thermal capacity required for rotating or linear loads
hp-sec/min

Wk_r^2 = Total system inertia reflected to brake, lb-ft²

N_B = Shaft speed at brake, rpm

n = Number of stops per minute, not less than 1

$$3.2 \times 10^6 = \text{Constant}$$

The rotating speed enters the formula as a squared function. Therefore, thermal requirements are of particular significance in systems where the brake will be operated at high speeds.

$$TC = \frac{E_T \times n}{550}$$

Where, TC = Thermal capacity required for overhauling loads
hp-sec/min

E_T = Total energy brake absorbs, ft-lb

n = Number of stops per minute, not less than 1

$$550 = \text{Constant}$$

For overhauling loads, the rate at which a brake is required to absorb and dissipate heat when frequently cycled is determined by the relationship:

Example 11 illustrates how the required thermal capacity would be determined for Example 4.

Example 11: Determine the thermal capacity required to stop a rotating load frequently.

Referring back to Example 4, the flywheel will be stopped 20 times per minute.

The required thermal capacity of the 6 lb-ft brake selected in this example is determined as follows.

The total inertial load the brake is to retard is 0.15 lb-ft². The shaft speed of the brake motor is 1,800 rpm. Therefore, the required thermal capacity is,

$$\begin{aligned} TC &= \frac{Wk_r^2 \times N_B^2 \times n}{3.2 \times 10^6} \\ &= \frac{0.15 \times 1,800^2 \times 20}{3.2 \times 10^6} \end{aligned}$$

$$TC = 3.0 \text{ hp-sec/min}$$

The 6 lb-ft brake selected in Example 4 should have a thermal capacity rating equal to or greater than 3.0 hp-sec/min.

A brake with greater thermal capacity will result in greater wear life.

If productivity is to be improved in Example 4 by increasing the cycle rate, the maximum number of stops per minute is determined by the rated thermal capacity of the brake. If the 6 lb-ft brake selected in Example 4 has rated thermal capacity of 9 hp-sec/min, the maximum permissible stops per minute would be determined by transposing the above formula to,

$$\begin{aligned}n_{\max} &= \frac{TC_{\text{rated}} \times (3.2 \times 10^6)}{WK_f^2 \times N_m^2} \\ &= \frac{9 \times (3.2 \times 10^6)}{0.15 \times 1,800^2} \\ n_{\max} &= 59 \text{ stops/min}\end{aligned}$$

So, the brake could be operated up to 36 times per minute without exceeding its ability to absorb and dissipate the heat generated by the frequent stops and meet the maximum solenoid cycle rating. *Cycle rate cannot exceed the solenoid cycle rate appearing in the catalog.*

Electrical Considerations

Please see Super-Mod® dimensional data section.

Environmental Considerations

Brakes with standard open enclosures when mounted on NEMA C-face motors are drip-proof, except where a manual release lever has a clearance opening in the housing. The standard enclosure is commonly used on open, drip-proof and enclosed motors operating indoors or in protected outdoor environments.

NEMA 4, IP 54 is available on most brake models and are commonly used for outdoor installations, or where there are moist, abrasive or dusty environments. Standard and severe duty NEMA 4 enclosures are available in some brake series.

Brakes of various styles and materials for above or below deck on ships and dockside installation are available. The materials are usually specified by the ship designers or Navy specification MIL-B-16392C. Brakes are also available to meet MIL-E-17807B for shipboard weapon and cargo elevators. Refer to Marine, Maritime and Navy catalog pages.

Brakes Listed by Underwriters Laboratories, Inc. are available for use in hazardous locations, including Class I, Groups C and D; and Class II, Groups E, F and G. Motor-mounted, hazardous-location electric disc brakes are listed only when mounted to a Listed hazardous-location motor of the same Class and Group at the motor manufacturer's facility, and where the combination has been accepted by UL. This procedure completes the hazardous duty assembly of the brake. However, foot-mounted hazardous-location disc brakes that are Listed are also available for coupling to a motor, and may be installed by anyone.

Hazardous-location brakes are *not* gasketed unless indicated in the brake description. The enclosure prevents flame propagation to the outside atmosphere through controlled clearances. Protection from weather and washdowns must be provided. If the brake is used in a high humidity or low temperature environment, internal electric heaters should be used.

Standard ambient temperature range for brake operation is from 20°F (-7°C) to 104°F (40°C). Refer to Thermal Ratings section for brake operation at higher ambient temperatures. Heaters may be available for brake operation at low ambient temperatures and high humidity environments. Ductile iron construction and heaters are recommended for prolonged cold climate use.

Conclusion

The spring-set, electrically released disc brake is an important accessory to electric motors used in cycling and holding operations. It is available in a wide variety of enclosures. In most applications, a brake requires no additional wiring, controls or auxiliary electrical equipment. It is simple to maintain since the replaceable items, the friction discs, can be easily changed.

Many spring-set motor brakes are equipped with features such as simple wear adjustment to provide optimum friction disc life, visual wear indicator, torque adjustment and manual release. Featured on some types of brakes is automatic adjustment to compensate for friction disc wear. This feature eliminates the need for periodic adjustment and is advantageous in remote or inaccessible locations. Not all of the brakes on the market provide all of these features, but there are many Stearns motor brakes offering these features.

Care should be exercised in properly selecting a brake giving due consideration to torque as well as environment and thermal requirements. On applications where all the pertinent information is not available, selection must be based on previous experience of the designer and user, as well as the brake manufacturer, and should be confirmed by tests under actual operating conditions. If the brake is selected with reasonable allowances made for extremes in operating conditions, it will perform its task with little attention or maintenance.

Formulas

The following formulas cover the basic calculations used in brake application engineering.

Required	Given	Formula
Full load motor torque (T_{flmt}), lb-ft	Horsepower (P), hp Shaft speed (N), rpm 5252 = Constant	$T_{flmt} = \frac{5252 \times P}{N}$
Average dynamic braking torque (T_d), lb-ft	Total inertia reflected to brake (Wk^2), lb-ft ² Shaft speed at brake (N), rpm Desired stopping time (t), seconds 308 = Constant	$T_d = \frac{Wk^2 \times N}{308 \times T}$
Static torque (T), lb-ft	Force (F), lb Pulley or drum radius, (R), ft	$T = F \times R$
Overhauling dynamic torque reflected to brake shaft (T_o), lb-ft	Weight of overhauling load (W), lb Linear velocity of descending load (V), ft/min Shaft speed at brake (N), rpm 0.158 = Constant	$T_o = \frac{0.158 \times W \times V}{N}$
Static torque of brake (T_s), lb-ft (General Guideline)	Dynamic braking torque required (T_d), lb-ft 0.8 = Constant (derating factor)	$T_s = \frac{T_d}{0.8}$
Inertia of rotating load reflected to brake shaft (Wk_b^2), lb-ft ²	Inertia of rotating load (Wk_L^2), lb-ft ² Shaft speed at load (N_L), rpm Shaft speed at brake (N_B), rpm	Equivalent $Wk_b^2 = Wk_L^2 \left(\frac{N_L}{N_B} \right)^2$
Equivalent inertia of linear moving load reflected to brake shaft (Wk_w^2), lb-ft ²	Weight of linear moving load (W), lb Linear velocity of load (V), ft/min Shaft speed at brake (N_B), rpm 2 = Constant	Equivalent $Wk_w^2 = W \left(\frac{V}{2\pi N_B} \right)^2$
Kinetic energy of rotating load, (KE_r), ft-lb	Inertia of rotating load reflected to brake shaft (Wk_b^2), lb-ft ² Shaft speed at brake (N_B), rpm 5875 = Constant	$KE_r = \frac{Wk_b^2 \times N_B^2}{5875}$
Kinetic energy of linear moving load (KE_l), ft-lb	Weight of load (W), lb Linear velocity of load (v), ft/sec g = Gravitational acceleration constant, 32.2 ft/sec ²	$KE_l = \frac{Wv^2}{2g}$
Change in potential energy (PE), ft-lb	Weight of overhauling load (W), lb Distance load travels (s), ft	$PE = Ws$
Total energy absorbed by brake (E_T), ft-lb	Total linear kinetic energy, (KE_L), ft-lb Total rotary kinetic energy (KE_R), ft-lb Potential energy converted to kinetic energy (PE), ft-lb	$E_T = KE_L + KE_R + PE$
Thermal capacity required for rotational or linear moving loads (TC), hp-sec/min	Total system inertia reflected to brake shaft (Wk_T^2), lb-ft ² Shaft speed at brake (N_B), rpm Number of stops per minute (n), not less than one 3.2×10^6 = Constant	$TC = \frac{Wk_T^2 \times N_B^2 \times n}{3.2 \times 10^6}$
Thermal capacity required for overhauling loads (TC), hp-sec/min	Total energy brake absorbs (E_T), ft-lb Number of stops per minute (n), not less than one 550 = Constant	$TC = \frac{E_T \times n}{550}$
Linear velocity, ft/min	N = rpm Diameter (D), ft	$V = N\pi D$